

CHAPTER 4

FOUNDATIONS

SECTION R401 GENERAL

R401.1 Application. The provisions of this chapter shall control the design and construction of the foundation and foundation spaces for all buildings. Wood foundations shall be designed and installed in accordance with AF&PA Report No. 7.

Exceptions:

1. The provisions of this chapter shall be permitted to be used for wood foundations only in the following situations:
 - 1.1. In buildings that have no more than two floors and a roof.
 - 1.2. When interior basement and foundation walls are provided at intervals not exceeding 50 feet.
2. In addition to the provisions of this chapter, the design and construction of foundations in areas prone to flooding as established by the local jurisdiction shall meet the provisions of Section R323.

Wood foundations in Seismic Design Categories D₁ and D₂ shall be designed in accordance with accepted engineering practice.

R401.2 Requirements. Foundation construction shall be capable of accommodating all loads according to Section R301 and of transmitting the resulting loads to the supporting soil. Where a construction joint is created between a concrete footing and stem wall, a means of connection shall be provided to accommodate lateral displacement. The connection shall be made by the use of a keyway or other method in accordance with accepted foundation design practices. Fill soils that support footings and foundations shall be designed, installed and tested in accordance with accepted engineering practice. Gravel fill used as footings for wood and precast concrete foundations shall comply with Section R403.

R401.3 Drainage. Surface drainage shall be diverted to a storm sewer conveyance or other approved point of collection so as to not create a hazard. Lots shall be graded so as to drain surface water away from foundation walls. The grade away from foundation walls shall fall a minimum of 6 inches (152 mm) within the first 10 feet (3048 mm).

Exception: Where lot lines, walls, slopes or other physical barriers prohibit 6 inches (152 mm) of fall within 10 feet (3048 mm), drains, swales, or other approved means shall be provided to ensure drainage away from the structure.

R401.4 Soil tests. In areas likely to have expansive, compressible, shifting or other unknown soil characteristics, the building official shall determine whether to require a soil test to determine the soil's characteristics at a particular location. This test shall be made by an approved agency using an approved method.

R401.4.1 Geotechnical evaluation. In lieu of a complete geotechnical evaluation, the load-bearing values in Table R401.4.1 shall be assumed.

**TABLE R401.4.1
PRESUMPTIVE LOAD-BEARING VALUES OF
FOUNDATION MATERIALS^a**

CLASS OF MATERIAL	LOAD-BEARING PRESSURE (pounds per square foot)
Crystalline bedrock	12,000
Sedimentary and foliated rock	4,000
Sandy gravel and/or gravel (GW and GP)	3,000
Sand, silty sand, clayey sand, silty gravel and clayey gravel (SW, SP, SM, SC, GM and GC)	2,000
Clay, sandy clay, silty clay, clayey silt, silt and sandy silt (CI, ML, MH and CH)	1,500 ^b

For SI: 1 pound per square foot = 0.0479 kN/m².

- a. When soil tests are required by Section R401.4, the allowable bearing capacities of the soil shall be part of the recommendations.
- b. Where the building official determines that in-place soils with an allowable bearing capacity of less than 1,500 psf are likely to be present at the site, the allowable bearing capacity shall be determined by a soils investigation.

R401.5 Compressible or shifting soil. When top or subsoils are compressible or shifting, such soils shall be removed to a depth and width sufficient to assure stable moisture content in each active zone and shall not be used as fill or stabilized within each active zone by chemical, dewatering, or presaturation.

SECTION R402 MATERIALS

R402.1 Wood foundations. Wood foundation systems shall be designed and installed in accordance with the provisions of this code.

R402.1.1 Fasteners. Fasteners used below grade to attach plywood to the exterior side of exterior basement or crawlspace wall studs, or fasteners used in knee wall construction, shall be of Type 304 or 316 stainless steel. Fasteners used above grade to attach plywood and all lumber-to-lumber fasteners except those used in knee wall construction shall be of Type 304 or 316 stainless steel, silicon bronze, copper, hot-dipped galvanized (zinc coated) steel nails, or hot-tumbled galvanized (zinc coated) steel nails. Electro galvanized steel nails and galvanized (zinc coated) steel staples shall not be permitted.

R402.1.2 Wood treatment. All lumber and plywood shall be treated in accordance with AWPA C22, and shall bear the label of an accredited agency showing 0.60 retention. Where lumber and/or plywood is cut or drilled after treatment, the treated surface shall be field treated with Copper Naphthenate, the concentration of which shall contain a minimum of 2 percent copper metal, by repeated brushing, dipping or soaking until the wood absorbs no more preservative.

R402.2 Concrete. Concrete shall have a minimum specified compressive strength as shown in Table R402.2. Concrete subject to weathering as indicated in Table R301.2(1) shall be air entrained as specified in Table R402.2. The maximum weight of

FOUNDATIONS

fly ash, other pozzolans, silica fume, or slag that is included in concrete mixtures for garage floor slabs and for exterior porches, carport slabs, and steps that will be exposed to deicing chemicals shall not exceed the percentages of the total weight of cementitious materials specified in ACI 318. Materials used to produce concrete and testing thereof shall comply with the applicable standards listed in ACI 318. In addition to the cements permitted by ACI 318, cement complying with ASTM C 1157 is permitted.

R402.3 Precast concrete. Approved precast concrete foundations shall be designed and installed in accordance with the provisions of this code and the manufacturer’s installation instructions.

**SECTION R403
FOOTINGS**

R403.1 General. All exterior walls shall be supported on continuous solid or fully grouted masonry or concrete footings, wood foundations, or other approved structural systems which shall be of sufficient design to accommodate all loads according to Section R301 and to transmit the resulting loads to the soil within the limitations as determined from the character of the soil. Footings shall be supported on undisturbed natural soils or engineered fill.

R403.1.1 Minimum size. Minimum sizes for concrete and masonry footings shall be as set forth in Table R403.1 and Figure R403.1(1). The footing width, *W*, shall be based on the load-bearing value of the soil in accordance with Table R401.4.1. Spread footings shall be at least 6 inches (152 mm) in thickness for foundation walls supporting one floor, 7 inches (178 mm) thick for foundation walls supporting two floors and 8 inches (203 mm) thick for foundation walls supporting three floors. Footing projections, *P*, shall be at least 2 inches (51 mm). The size of footings supporting piers and columns shall be based on the tributary load and allowable soil pressure in accordance with Table R401.4.1. For isolated footings, see Section 403.1.2. Footings for wood foundations shall be in accordance with the details set forth in Section R403.2, and Figures R403.1(2) and R403.1(3).

**TABLE R403.1
MINIMUM WIDTH OF CONCRETE OR MASONRY FOOTINGS
(inches)**

	LOAD-BEARING VALUE OF SOIL (psf) ^a			
	1,000	1,500	2,000	3,000
Conventional light-frame construction				
1-story	18	12	9	6
2-story	23	15	12	8
3-story	27	18	14	9
4-inch brick veneer over light frame construction or 8-inch hollow concrete masonry				
1-story	23	15	10	7
2-story	29	19	13	9
3-story	35	23	16	11
8-inch solid concrete or masonry, or fully grouted masonry				
1-story	26	17	13	9
2-story	36	23	18	12
3-story	45	30	23	16

For SI: 1 inch = 25.4 mm, 1 pound per square foot = 0.0479 kN/m².

a. Footings supporting foundations may support a roof in addition to the stipulated number of floors. Footings supporting roofs only shall be as required for supporting one floor.

R403.1.2 Isolated footings. Plain isolated square or round footings shall be permitted subject to the limitations in Sections R403.1.2.1 and R403.1.2.2.

R403.1.2.1 Isolated footings in the crawlspace. Plain concrete isolated footings supporting a single floor system whose total loads do not exceed 50 pounds per square foot (2394 Pa) (40 pounds live load, 10 pounds dead load) shall be a minimum size of 18 inches in diameter by 8 inches in depth (457 mm by 203 mm) or 1.3 feet square in plan area by 8 inches in depth (0.12 m² by 203 mm) when the following conditions are met:

1. Crawl spaces are enclosed by a continuous concrete or masonry foundation.

**TABLE R402.2
MINIMUM SPECIFIED COMPRESSIVE STRENGTH OF CONCRETE**

TYPE OR LOCATIONS OF CONCRETE CONSTRUCTION	MINIMUM SPECIFIED COMPRESSIVE STRENGTH ^a (<i>f'</i> _c)		
	Weathering potential ^b		
	Negligible	Moderate	Severe
Basement walls, foundations and other concrete not exposed to the weather	2,500	2,500	2,500 ^c
Basement slabs and interior slabs on grade, except garage floor slabs	2,500	2,500	2,500 ^c
Basement walls, foundation walls, exterior walls and other vertical concrete work exposed to the weather	2,500	3,000 ^d	3,000 ^d
Porches, carport slabs and steps exposed to the weather, and garage floor slabs	2,500	3,000 ^{d,e}	3,500 ^{d,e}

For SI: 1 pound per square inch = 6.895 kPa.

a. At 28 days psi.

b. See Table R301.2(1) for weathering potential.

c. Concrete in these locations that may be subject to freezing and thawing during construction shall be air-entrained concrete in accordance with Note d.

d. Concrete shall be air entrained. Total air content (percent by volume of concrete) shall not be less than 5 percent or more than 7 percent.

e. See Section R402.2 for minimum cement content.

FOUNDATIONS

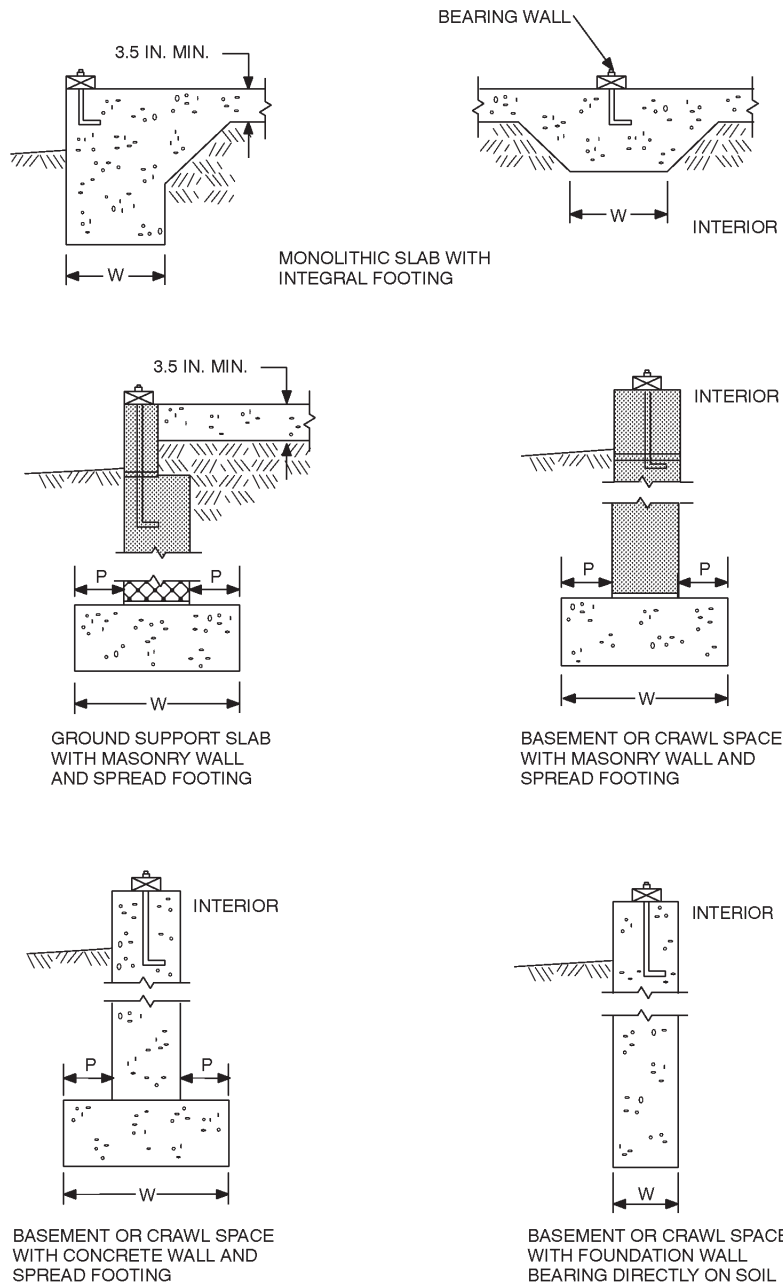

For SI: 1 inch = 25.4 mm.

FIGURE R403.1(1)
CONCRETE AND MASONRY FOUNDATION DETAILS

FOUNDATIONS

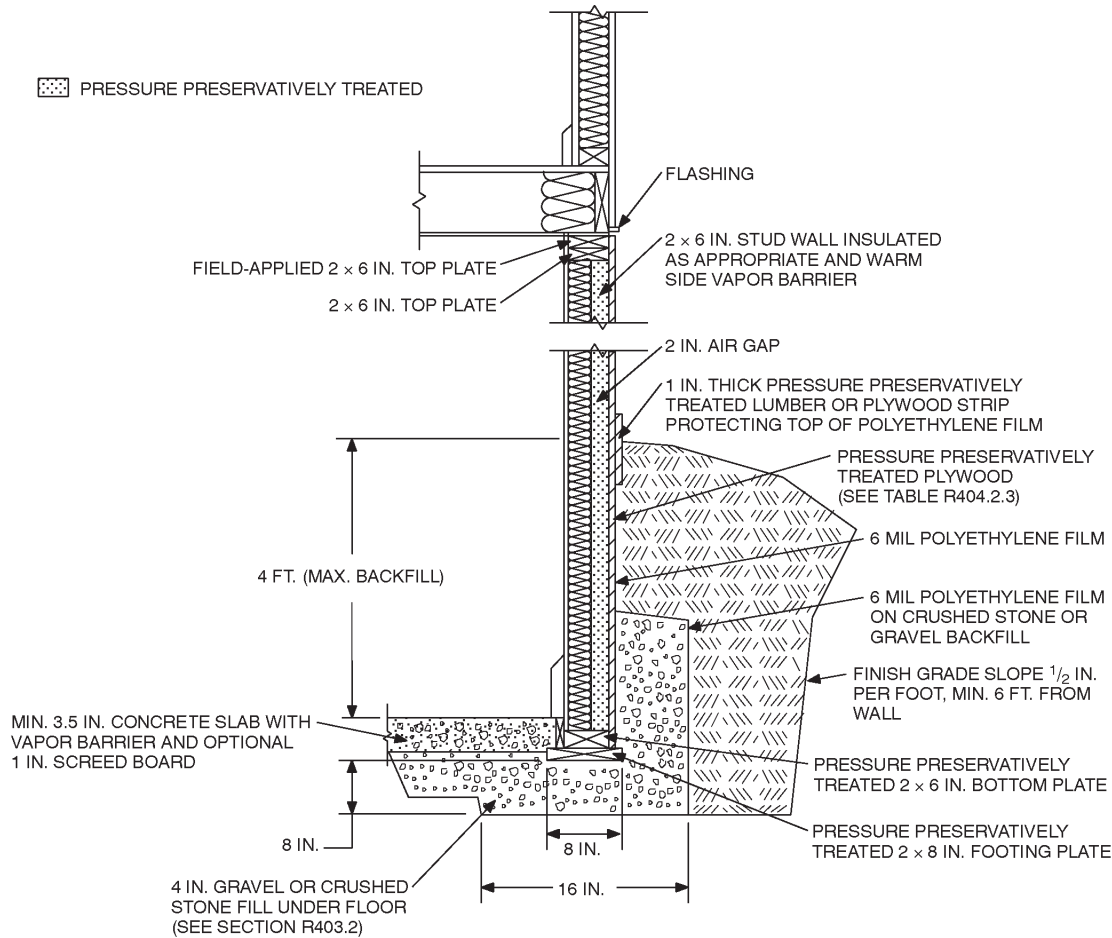

For SI: 1 inch = 25.4 mm, 1 foot = 304.8 mm, 1 mil = 0.0254 mm.

FIGURE R403.1(2)
PERMANENT WOOD FOUNDATION BASEMENT WALL SECTION

- Floor beam spacing does not exceed 48 inches (1219 mm) on center and the maximum size of wood floor girders is 4 inches by 8 inches (102 mm by 203 mm) or 6 inches by 6 inches (152 mm by 152 mm) [see Table 502.5(3)]

Plain concrete isolated footings supporting other floor loads in an enclosed crawl space shall not exceed 6.25 square feet in plan area by 15 inches in depth (1905 mm by 381 mm) or 34 inches in diameter by 17 inches in depth (864 mm by 432 mm). When the axial load exceeds 9,000 pounds (4.08 kg), the footing shall be designed.

R403.1.2.2 Outside isolated footings. Plain concrete isolated footings located outside of an enclosed crawl space shall not exceed 6.25 square feet in plan area by 15 inches in depth (19.5 mm by 381 mm) or 34 inches in diameter by 17 inches in depth (864 mm by 432 mm). When the axial load exceeds 9,000 pounds (4.08 kg), the footing shall be designed. The footing shall meet the frost depth requirements of Table R301.2(1).

R403.1.3 Continuous footings in Seismic Design Categories D₁ and D₂. The braced wall panels at exterior walls of

all buildings located in Seismic Design Categories D₁ and D₂ shall be supported by continuous footings. For support of interior braced wall lines, see Section R602.10.9.

R403.1.4 Seismic reinforcing. Concrete footings located in Seismic Design Categories D₁ and D₂, as established in Table R301.2(1), shall have minimum reinforcement. Bottom reinforcement shall be located a minimum of 3 inches (76 mm) clear from the bottom of the footing.

In Seismic Design Categories D₁ and D₂ where a construction joint is created between a concrete footing and stem wall, a minimum of one No. 4 bar shall be provided at not more than 4 feet (1219 mm) on center. The vertical bar shall extend to 3 inches (76 mm) clear of the bottom of the footing, have a standard hook and extend a minimum of 14 inches (357 mm) into the stem wall.

In Seismic Design Categories D₁ and D₂ where a grouted masonry stem wall is supported on a concrete footing and stem wall, a minimum of one No. 4 bar shall be provided at not more than four feet on center. The vertical bar shall extend to 3 inches (76 mm) clear of the bottom of the footing and have a standard hook.

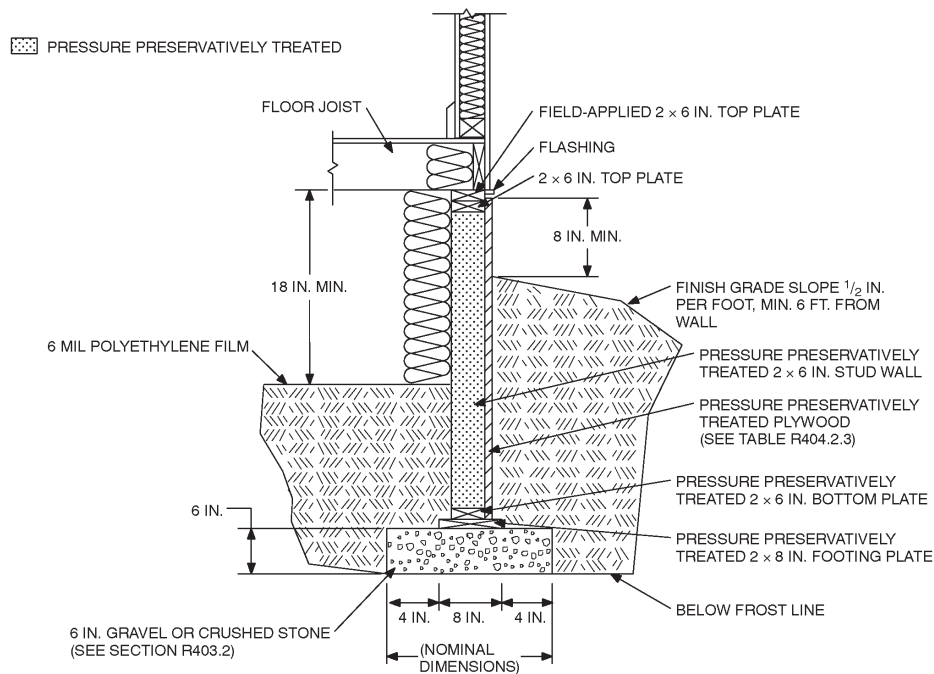

For SI: 1 inch = 25.4 mm, 1 foot = 304.8 mm, 1 mil = 0.0254 mm.

FIGURE R403.1(3)
PERMANENT WOOD FOUNDATION CRAWL SPACE SECTION

In Seismic Design Categories D_1 and D_2 masonry stem walls without solid grout and vertical reinforcing shall not be permitted.

R403.1.4.1 Foundations with stemwalls. Foundations with stemwalls shall be provided with a minimum of one No. 4 bar within 12 inches (305 mm) of the top of the wall and one No. 4 bar at the bottom of the footing.

Exception: Foundations constructed monolithically shall be permitted to have a minimum of two No. 4 bars placed in the footing.

R403.1.4.2 Slabs-on-ground with turned-down footings. Slabs-on-ground with turned down footings shall have a minimum of one No. 4 bar at the top and bottom of the footing.

Exception: For slabs-on-ground cast monolithically with a footing, one No. 5 bar or two No. 4 bars shall be located in the middle third of the footing depth.

R403.1.5 Minimum depth. All exterior footings shall be placed at least 12 inches (305 mm) below the finished grade on undisturbed ground surface. Where applicable, the depth of footings shall also conform to Sections R403.1.5.1 through R403.1.5.2.

R403.1.5.1 Frost protection. Except where otherwise protected from frost, foundation walls, piers and other permanent supports of buildings and structures shall be protected from frost by one or more of the following methods:

1. Extending below the frost line specified in Table R301.2(1);
2. Constructing in accordance with Section R403.3;
3. Constructing in accordance with ASCE 32-01; and
4. Erected on solid rock.

Exceptions:

1. Freestanding accessory structures with an area of 400 square feet (37 m²) or less and an eave height of 10 feet (3048 mm) or less shall not be required to be protected.
2. Decks not supported by a dwelling need not be provided with footings that extend below the frost line.

Footings shall not bear on frozen soil unless such frozen condition is of a permanent character.

R403.1.5.2 Seismic conditions. In Seismic Design Categories D_1 and D_2 , interior footings supporting required braced wall lines and cast monolithically with a slab on grade shall extend to a depth of not less than 12 inches (305 mm) below the top of slab.

R403.1.6 Slope. The top surface of footings shall be level. The bottom surface of footings shall not have a slope exceeding one unit vertical in 10 units horizontal (10-percent slope). Footings shall be stepped where it is necessary to change the elevation of the top surface of the footings or where the slope of the bottom surface of the footings will exceed one unit vertical in ten units horizontal (10-percent slope).

FOUNDATIONS

R403.1.7 Grounding electrodes. When concrete reinforcing bars are installed in concrete footings, the following requirements shall be met to provide for a grounding electrode system:

1. Uncoated No. 4 reinforcing bar installed not less than 3 inches (76 mm) from the bottom of the footing and not less than 20 feet (6096 mm) in length encased with a minimum of 2 inches (51 mm) of concrete.
2. An uncoated No. 4 reinforcing bar stubbed up at least 12 inches (305 mm) above the floor plate line and tightly attached to the reinforcing bar located in the footing. The spliced lap of the stubbed up bar to the footing bar shall be a minimum of 12 inches (305 mm).

R403.1.8 Foundation anchorage. When braced wall panels are supported directly on continuous foundations, the wall wood sill plate or cold-formed steel bottom track shall be anchored to the foundation in accordance with this section. In Seismic Design Categories D_1 and D_2 , the additional anchorage requirements of Section R602.11.1 shall apply for wood framing.

The wood sole plate at exterior walls on monolithic slabs and wood sill plate shall be anchored to the foundation with anchor bolts spaced a maximum of 6 feet (1829 mm) on center. There shall be a minimum of two bolts per plate section with one bolt located not more than 12 inches (305 mm) or less than seven bolt diameters from each end of the plate section. In Seismic Design Categories D_1 and D_2 , anchor bolts shall also be spaced at 6 feet (1829 mm) on center and located within 12 inches (305 mm) from the ends of each plate section at interior braced wall lines when required by Section R602.10.9 to be supported on a continuous foundation. Bolts shall be at least $\frac{1}{2}$ inch (12.7 mm) in diameter and shall extend a minimum of 7 inches (178 mm) into masonry or concrete. Interior bearing wall sole plates on monolithic slab foundations shall be positively anchored with approved fasteners. A nut and washer shall be tightened on each bolt to the plate. Sills and sole plates shall be protected against decay and termites where required by Sections R318 and R319. Cold-formed steel framing systems shall be fastened to the wood sill plates or anchored directly to the foundation as required in Section R505.3.1 or R603.1.1.

Exception: Foundation anchor straps, spaced as required to provide equivalent anchorage to $\frac{1}{2}$ -inch-diameter (12.7 mm) anchor bolts.

R403.1.8.1 Foundation anchorage in Seismic Design Categories C, D_1 and D_2 . In addition to the requirements of Section R403.1.8, the following requirements shall apply to wood-frame structures in Seismic Design Categories D_1 and D_2 and wood-frame townhouses in Seismic Design Category C.

1. Plate washers conforming to Section R602.11.1 shall be used on each bolt.
2. Interior braced wall plates shall have anchor bolts spaced at not more than 6 feet (1829 mm) on center and located within 12 inches (305 mm) from the ends of each plate section when supported on a continuous foundation required by Section R602.10.9.

3. In Seismic Design Category D_2 , the maximum anchor bolt spacing shall be 4 feet (1219 mm) for buildings over two stories in height.
4. Stepped cripple walls shall conform to Section R602.11.3.
5. Where continuous wood foundations in accordance with Section R404.2 are used, the force transfer shall have a capacity equal to or greater than the connections required by Section R602.11.1 or the braced wall panel shall be connected to the wood foundations in accordance with the braced wall panel-to-floor fastening requirements of Table 602.3(1).

R403.1.9 Footings on or adjacent to slopes. The placement of buildings and structures on or adjacent to slopes steeper than 1 unit vertical in 3 units horizontal (33.3-percent slope) shall conform to Sections R403.1.9.1 through R403.1.9.4.

R403.1.9.1 Building clearances from ascending slopes. In general, buildings below slopes shall be set a sufficient distance from the slope to provide protection from slope drainage, erosion and shallow failures. Except as provided in Section R403.1.9.4 and Figure R403.1.9.1, the following criteria will be assumed to provide this protection. Where the existing slope is steeper than one unit vertical in one unit horizontal (100-percent slope), the toe of the slope shall be assumed to be at the intersection of a horizontal plane drawn from the top of the foundation and a plane drawn tangent to the slope at an angle of 45 degrees (0.79 rad) to the horizontal. Where a retaining wall is constructed at the toe of the slope, the height of the slope shall be measured from the top of the wall to the top of the slope.

R403.1.9.2 Footing setback from descending slope surfaces. Footings on or adjacent to slope surfaces shall be founded in material with an embedment and setback from the slope surface sufficient to provide vertical and lateral support for the footing without detrimental settlement. Except as provided in Section R403.1.9.4 and Figure R403.1.9.1, the following setback is deemed adequate to meet the criteria. Where the slope is steeper than one unit vertical in one unit horizontal (100-percent slope), the required setback shall be measured from an imaginary plane 45 degrees (0.79 rad) to the horizontal, projected upward from the toe of the slope.

R403.1.9.3 Foundation elevation. On graded sites, the top of any exterior foundation shall extend above the elevation of the street gutter at point of discharge or the inlet of an approved drainage device a minimum of 12 inches (305 mm) plus 2 percent. Alternate elevations are permitted subject to the approval of the building official, provided it can be demonstrated that required drainage to the point of discharge and away from the structure is provided at all locations on the site.

R403.1.9.4 Alternate setback and clearances. Alternate setbacks and clearances are permitted, subject to the approval of the building official. The building official is permitted to require an investigation and recommendation of a qualified engineer to demonstrate that the intent

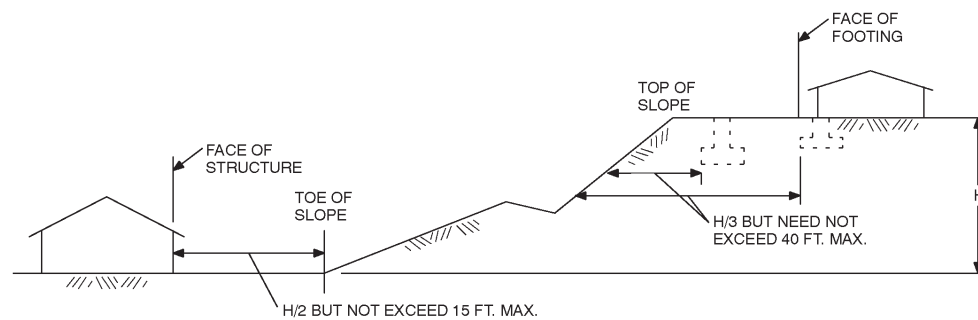

For SI: 1 foot = 304.8 mm.

FIGURE R403.1.9.1
FOUNDATION CLEARANCE FROM SLOPES

of this section has been satisfied. Such an investigation shall include consideration of material, height of slope, slope gradient, load intensity and erosion characteristics of slope material.

- || **R403.1.10 Foundations on expansive soils.** Foundation and floor slabs for buildings located on expansive soils shall be designed in accordance with Section 1805.8 of the *Oregon Structural Specialty Code*.

Exception: Slab-on-ground and other foundation systems which have performed adequately in soil conditions similar to those encountered at the building site are permitted subject to the approval of the building official.

- || **R403.1.10.1 Expansive soils classifications.** Soils meeting all four of the following provisions shall be considered expansive, except that tests to show compliance with Items 1, 2 and 3 shall not be required if the test prescribed in Item 4 is conducted:

1. Plasticity Index (PI) of 15 or greater, determined in accordance with ASTM D 4318.
2. More than 10 percent of the soil particles pass a No. 200 sieve (75 mm), determined in accordance with ASTM D 422.
3. More than 10 percent of the soil particles are less than 5 micrometers in size, determined in accordance with ASTM D 422.
4. Expansion Index greater than 20, determined in accordance with ASTM D4829.

R403.2 Footings for wood foundations. Footings for wood foundations shall be in accordance with Figures R403.1(2) and R403.1(3). Gravel shall be washed and well graded. The maximum size stone shall not exceed $\frac{3}{4}$ inch (19.1 mm). Gravel shall be free from organic, clayey or silty soils. Sand shall be coarse, not smaller than $\frac{1}{16}$ -inch (1.6 mm) grains and shall be free from organic, clayey or silty soils. Crushed stone shall have a maximum size of $\frac{1}{2}$ inch (12.7 mm).

R403.3 Frost protected shallow foundations. For buildings where the monthly mean temperature of the building is maintained at a minimum of 64°F (18°C), footings are not required to extend below the frost line when protected from frost by insulation in accordance with Figure R403.3(1) and Table R403.3. Foundations protected from frost in accordance with Figure R403.3(1) and Table R403.3 shall not be used for unheated spaces such as porches, utility rooms, garages and car-

ports, and shall not be attached to basements or crawl spaces that are not maintained at a minimum monthly mean temperature of 64°F (18°C).

Materials used below grade for the purpose of insulating footings against frost shall be labeled as complying with ASTM C 578.

R403.3.1 Foundations adjoining frost protected shallow foundations. Foundations that adjoin frost protected shallow foundations shall be protected from frost in accordance with Section R403.1.4.

R403.3.1.1 Attachment to unheated slab-on-ground structure. Vertical wall insulation and horizontal insulation of frost protected shallow foundations that adjoin a slab-on-ground foundation that does not have a monthly mean temperature maintained at a minimum of 64°F (18°C), shall be in accordance with Figure R403.3(3) and Table R403.3. Vertical wall insulation shall extend between the frost protected shallow foundation and the adjoining slab foundation. Required horizontal insulation shall be continuous under the adjoining slab foundation and through any foundation walls adjoining the frost protected shallow foundation. Where insulation passes through a foundation wall, it shall either be of a type complying with this section and having bearing capacity equal to or greater than the structural loads imposed by the building, or the building shall be designed and constructed using beams, lintels, cantilevers or other means of transferring building loads such that the structural loads of the building do not bear on the insulation.

R403.3.1.2 Attachment to heated structure. Where a frost protected shallow foundation abuts a structure that has a monthly mean temperature maintained at a minimum of 64°F (18°C), horizontal insulation and vertical wall insulation shall not be required between the frost protected shallow foundation and the adjoining structure. Where the frost protected shallow foundation abuts the heated structure, the horizontal insulation and vertical wall insulation shall extend along the adjoining foundation in accordance with Figure R403.3(4) a distance of not less than Dimension A in Table R403.3.

Exception: Where the frost protected shallow foundation abuts the heated structure to form an inside corner, vertical insulation extending along the adjoining foundation is not required.

FOUNDATIONS

TABLE R403.3
MINIMUM INSULATION REQUIREMENTS FOR FROST-PROTECTED FOOTINGS IN HEATED BUILDINGS^a

AIR FREEZING INDEX (°F-days) ^b	VERTICAL INSULATION R-VALUE ^{c,d}	HORIZONTAL INSULATION R-VALUE ^{c,e}		HORIZONTAL INSULATION DIMENSIONS PER FIGURE R403.3(1) (inches)		
		Along walls	At corners	A	B	C
1,500 or less	4.5	Not required	Not required	Not required	Not required	Not required
2,000	5.6	Not required	Not required	Not required	Not required	Not required
2,500	6.7	1.7	4.9	12	24	40
3,000	7.8	6.5	8.6	12	24	40
3,500	9.0	8.0	11.2	24	30	60
4,000	10.1	10.5	13.1	24	36	60

- a. Insulation requirements are for protection against frost damage in heated buildings. Greater values may be required to meet energy conservation standards. Interpolation between values is permissible.
- b. See Figure R403.3(2) for Air Freezing Index values.
- c. Insulation materials shall provide the stated minimum R-values under long-term exposure to moist, below-ground conditions in freezing climates. The following R-values shall be used to determine insulation thicknesses required for this application: Type II expanded polystyrene—2.4R per inch; Type IV extruded polystyrene—4.5R per inch; Type VI extruded polystyrene—4.5R per inch; Type IX expanded polystyrene—3.2R per inch; Type X extruded polystyrene—4.5R per inch.
- d. Vertical insulation shall be expanded polystyrene insulation or extruded polystyrene insulation.
- e. Horizontal insulation shall be extruded polystyrene insulation.

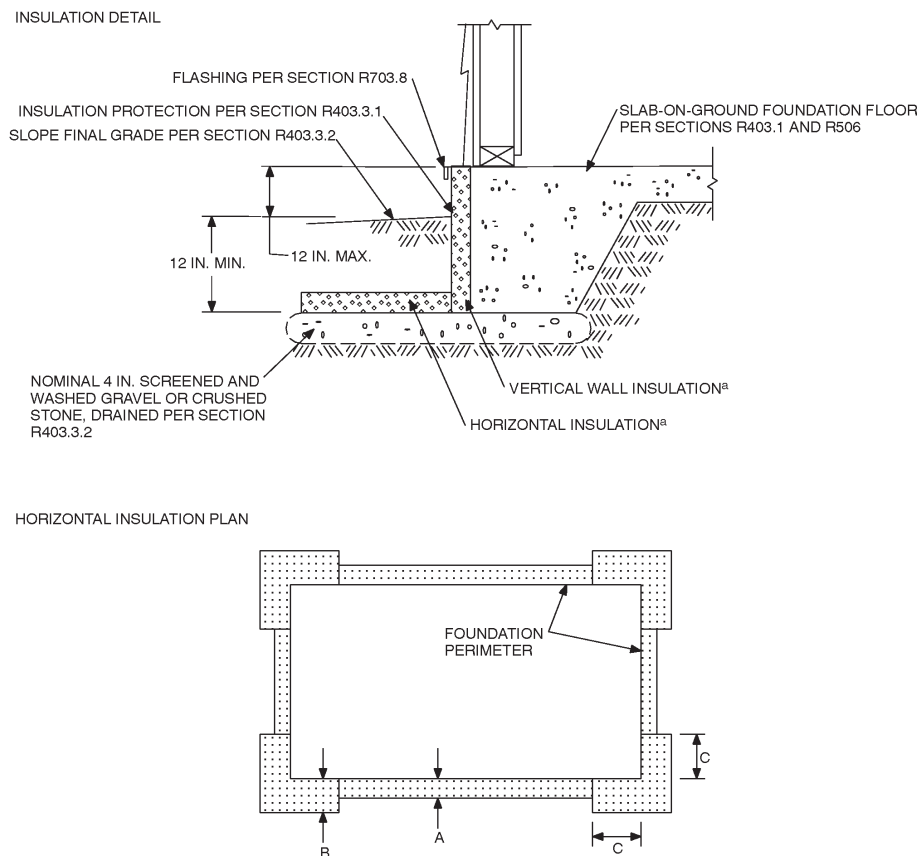

For SI: 1 inch = 25.4 mm.

- a. See Table R403.3 for required dimensions and R-values for vertical and horizontal insulation.

FIGURE R403.3(1)
INSULATION PLACEMENT FOR FROST-PROTECTED FOOTINGS IN HEATED BUILDINGS

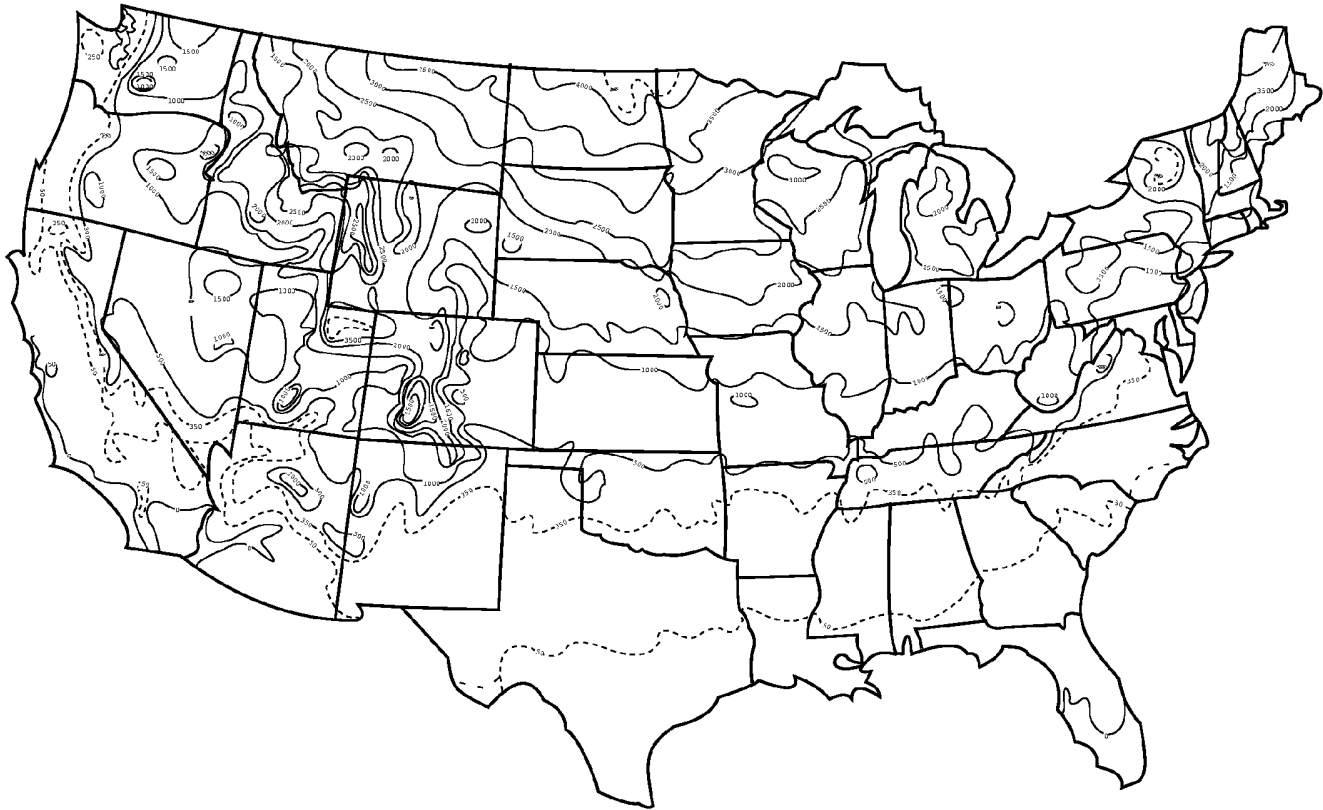

For SI: $^{\circ}\text{C} = [(^{\circ}\text{F}) - 32] / 1.8$.

NOTE: The air-freezing index is defined as cumulative degree days below 32°F. It is used as a measure of the combined magnitude and duration of air temperature below freezing. The index was computed over a 12-month period (July-June) for each of the 3,044 stations used in the above analysis. Data from the 1951-80 period were fitted to a Weibull probability distribution to produce an estimate of the 100-year return period.

FIGURE R403.3(2)
AIR-FREEZING INDEX
AN ESTIMATE OF THE 100-YEAR RETURN PERIOD

FOUNDATIONS

INSULATION DETAIL

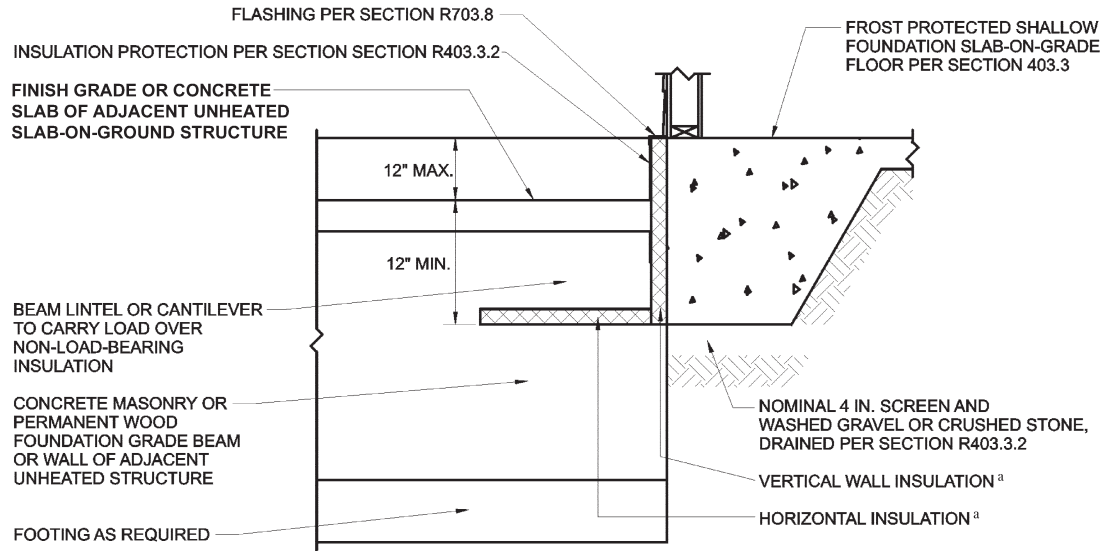

HORIZONTAL INSULATION PLAN

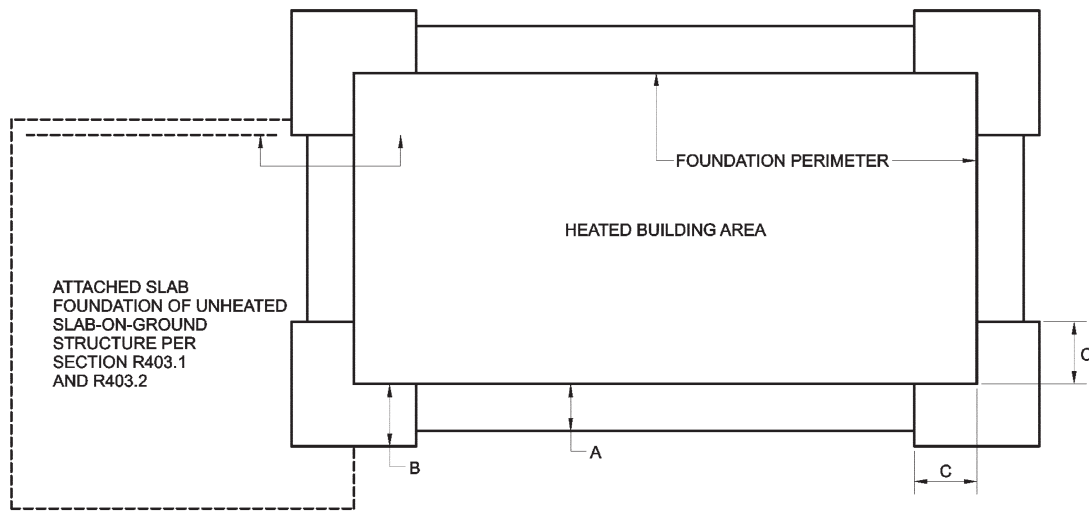

For SI: 1 inch = 25.4 mm.

a. See Table R403.3 for required dimensions and *R*-values for vertical and horizontal insulation.

FIGURE R403.3(3)
INSULATION PLACEMENT FOR FROST-PROTECTED FOOTINGS
ADJACENT TO UNHEATED SLAB-ON-GROUND STRUCTURE

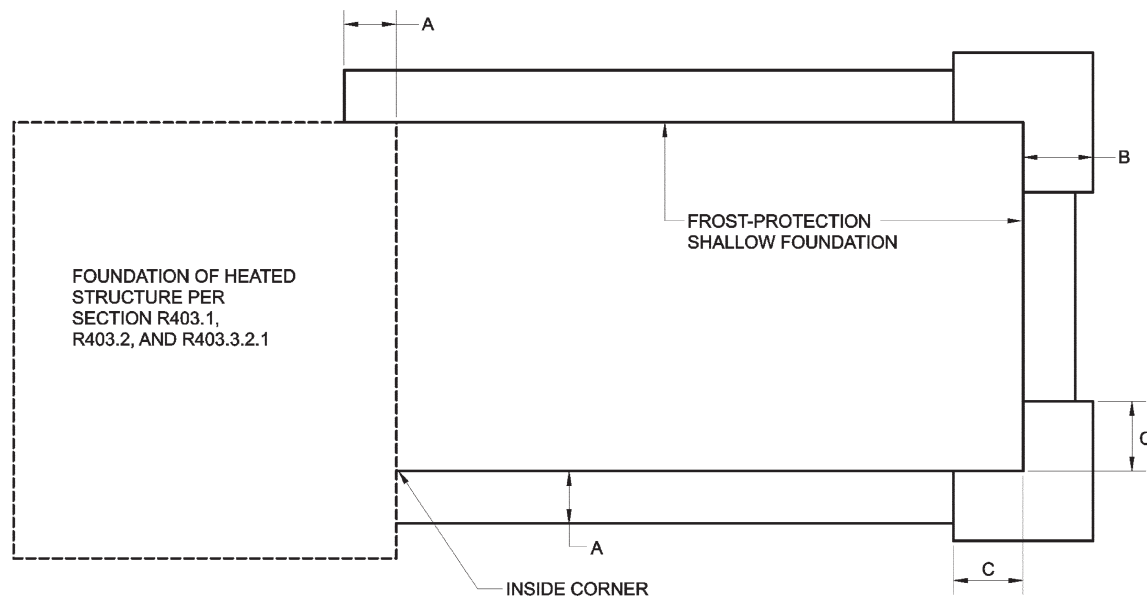

FIGURE R403.3(4)
INSULATION PLACEMENT FOR FROST-PROTECTED
FOOTINGS ADJACENT TO HEATED STRUCTURE

R403.3.2 Protection of horizontal insulation below ground. Horizontal insulation placed less than 12 inches (305 mm) below the ground surface or that portion of horizontal insulation extending outward more than 24 inches (610 mm) from the foundation edge shall be protected against damage by use of a concrete slab or asphalt paving on the ground surface directly above the insulation or by cementitious board, plywood rated for below-ground use, or other approved materials placed below ground, directly above the top surface of the insulation.

R403.3.3 Drainage. Final grade shall be sloped in accordance with Section R401.3. In other than Group I Soils, as detailed in Table R405.1, gravel or crushed stone beneath horizontal insulation below ground shall drain to daylight or into an approved sewer system.

R403.3.4 Termite damage. The use of foam plastic in areas of “very heavy” termite infestation probability shall be in accordance with Section R320.4.

SECTION R404 FOUNDATION WALLS

R404.1 Concrete and masonry foundation walls. Concrete and masonry foundation walls shall be selected and constructed in accordance with the provisions of this section or in accordance with ACI 318, NCMA TR68-A or ACI 530/ASCE 5/TMS 402 or other approved structural standards. When ACI 318 or ACI 530/ASCE 5/TMS 402 or the provisions of this section are used to design concrete or masonry foundation walls, project drawings, typical details and specifications are not required to bear the seal of the architect or engineer responsible for design, unless otherwise required by the state law of the jurisdiction having authority.

R404.1.1 Masonry foundation walls. Concrete masonry and clay masonry foundation walls shall be constructed as set forth in Tables R404.1.1(1), R404.1.1(2), R404.1.1(3) and R404.1.1(4) and shall also comply with the provisions of this section and the applicable provisions of Sections R606, R607 and R608. In Seismic Design Categories D_1 and D_2 , concrete masonry and clay masonry foundation walls shall comply with Section R404.1.4. Rubble stone masonry foundation walls shall be constructed in accordance with Sections R404.1.8 and R606.2.2. Rubble stone masonry walls shall not be used in Seismic Design Categories D_1 and D_2 .

R404.1.2 Concrete foundation walls. Concrete foundation walls shall be constructed as set forth in Tables R404.1.1(1), R404.1.1(2), R404.1.1(3) and R404.1.1(4), and shall also comply with the provisions of this section and the applicable provisions of Section R402.2. In Seismic Design Categories D_1 and D_2 , concrete foundation walls shall comply with Section R404.1.4.

R404.1.3 Design required. A design in accordance with accepted engineering practice shall be provided for concrete or masonry foundation walls when any of the following conditions exist:

1. Walls are subject to hydrostatic pressure from groundwater.
2. Walls supporting more than 48 inches (1219 mm) of unbalanced backfill that do not have permanent lateral support at the top and bottom.

R404.1.4 Seismic Design Categories D_1 and D_2 . In addition to the requirements of Table R404.1.1(1), plain concrete and plain masonry foundation walls located in

FOUNDATIONS

Seismic Design Categories D₁ and D₂, as established in Table R301.2 (1), shall comply with the following:

1. Minimum reinforcement shall consist of one No. 4 (No. 13) horizontal bar located in the upper 12 inches (305 mm) of the wall,
2. Wall height shall not exceed 8 feet (2438 mm),
3. Height of unbalanced backfill shall not exceed 4 feet (1219 mm), and
4. A minimum thickness of 7.5 inches (191 mm) is required for plain concrete foundation walls except that a minimum thickness of 6 inches (152 mm) shall be permitted for plain concrete foundation walls with a maximum height of 4 feet, 6 inches (1372 mm).

5. Plain masonry foundation walls shall be a minimum of 8 inches (203 mm) thick.

Vertical reinforcement for masonry stem walls shall be tied to the horizontal reinforcement in the footings. Masonry stem walls located in Seismic Design Categories D₁ and D₂ shall have a minimum vertical reinforcement of one No. 3 bar located a maximum of 4 feet (1220 mm) on center in grouted cells.

Foundation walls located in Seismic Design Categories D₁ and D₂, as established in Table R301.2(1), supporting more than 4 feet (1219 mm) of unbalanced backfill or exceeding 8 feet (2438 mm) in height shall be constructed in accordance with Table R404.1.1(2), R404.1.1(3) or R404.1.1(4) and shall have two No. 4 (No. 13) horizontal bars located in the upper 12 inches (305 mm) of the wall.

**TABLE R404.1.1(1)
PLAIN CONCRETE AND PLAIN MASONRY FOUNDATION WALLS^h**

MAXIMUM WALL HEIGHT (feet)	MAXIMUM UNBALANCED BACKFILL HEIGHT ^c (feet)	PLAIN CONCRETE MINIMUM NOMINAL WALL THICKNESS (inches)			PLAIN MASONRY ^a MINIMUM NOMINAL WALL THICKNESS (inches)		
		Soil classes ^b					
		GW, GP, SW and SP	GM, GC, SM, SM-SC and ML	SC, MH, ML-CL and inorganic CL	GW, GP, SW and SP	GM, GC, SM, SM-SC and ML	SC, MH, ML-CL and inorganic CL
5	4	6	6	6	6 solid ^d or 8	6 solid ^d or 8	6 solid ^d or 8
	5	8	8	8	8	8	10
6	4	6	6	6	6 solid ^d or 8	6 solid ^d or 8	6 solid ^d or 8
	5	8	8	8	8	8	10
	6	8	8 ^g	8 ^g	8	10	12
7	4	8	8	8	8	8	8
	5	8	8	8 ^g	8	10	10
	6	8	8	8	10	12	10 solid ^d
	7	8	8	10	12	10 solid ^d	12 solid ^d
8	4	8	8	8	8	8	8
	5	8	8	8	8	10	12
	6	8 ^h	8	10	10	12	12 solid ^d
	7	8	10	10	12	12 solid ^d	Footnote e
9	8	10	10	12	10 solid ^d	12 solid ^d	Footnote e
	4	8	8	8	8	8	8
	5	8	8 ^g	8	8	10	12
	6	8	8	10	10	12	12 solid ^d
	7	8	10	10	12	12 solid ^d	Footnote e
8	10	10	12	12 solid ^d	Footnote e	Footnote e	
9	10	12	Footnote f	Footnote e	Footnote e	Footnote e	

For SI: 1 inch = 25.4 mm, 1 foot = 304.8 mm, 1 pound per square inch = 6.895 Pa.

- a. Mortar shall be Type M or S and masonry shall be laid in running bond. UngROUTED hollow masonry units are permitted except where otherwise indicated.
- b. Soil classes are in accordance with the Unified Soil Classification System. Refer to Table R405.1.
- c. Unbalanced backfill height is the difference in height of the exterior and interior finish ground levels. Where an interior concrete slab is provided, the unbalanced backfill height shall be measured from the exterior finish ground level to the top of the interior concrete slab.
- d. Solid grouted hollow units or solid masonry units.
- e. Wall construction shall be in accordance with Table R404.1.1(2) or a design shall be provided.
- f. A design is required.
- g. Thickness may be 6 inches, provided minimum specified compressive strength of concrete, f'_c , is 4,000 psi.
- h. Minimum thickness of walls shall be 6 inches (152 mm) for wall supporting one floor, 8 inches (203 mm) supporting two floors and 10 inches (254 mm) supporting three floors.

TABLE R404.1.1(2)
REINFORCED CONCRETE AND MASONRY^a FOUNDATION WALLS

MAXIMUM WALL HEIGHT (feet)	MAXIMUM UNBALANCED BACKFILL HEIGHT ^e (feet)	MINIMUM VERTICAL REINFORCEMENT SIZE AND SPACING ^{b,c} FOR 8-INCH NOMINAL WALL THICKNESS		
		Soil classes ^d		
		GW, GP, SW and SP soils	GM, GC, SM, SM-SC and ML soils	SC, MH, ML-CL and inorganic CL soils
6	5	#4 at 48" o.c.	#4 at 48" o.c.	#4 at 48" o.c.
	6	#4 at 48" o.c.	#4 at 40" o.c.	#5 at 48" o.c.
7	4	#4 at 48" o.c.	#4 at 48" o.c.	#4 at 48" o.c.
	5	#4 at 48" o.c.	#4 at 48" o.c.	#4 at 40" o.c.
	6	#4 at 48" o.c.	#5 at 48" o.c.	#5 at 40" o.c.
	7	#4 at 40" o.c.	#5 at 40" o.c.	#6 at 48" o.c.
8	5	#4 at 48" o.c.	#4 at 48" o.c.	#4 at 40" o.c.
	6	#4 at 48" o.c.	#5 at 48" o.c.	#5 at 40" o.c.
	7	#5 at 48" o.c.	#6 at 48" o.c.	#6 at 40" o.c.
	8	#5 at 40" o.c.	#6 at 40" o.c.	#6 at 24" o.c.
9	5	#4 at 48" o.c.	#4 at 48" o.c.	#5 at 48" o.c.
	6	#4 at 48" o.c.	#5 at 48" o.c.	#6 at 48" o.c.
	7	#5 at 48" o.c.	#6 at 48" o.c.	#6 at 32" o.c.
	8	#5 at 40" o.c.	#6 at 32" o.c.	#6 at 24" o.c.
	9	#6 at 40" o.c.	#6 at 24" o.c.	#6 at 16" o.c.

For SI: 1 inch = 25.4 mm, 1 foot = 304.8 mm.

- Mortar shall be Type M or S and masonry shall be laid in running bond.
- Alternative reinforcing bar sizes and spacings having an equivalent cross-sectional area of reinforcement per lineal foot of wall shall be permitted provided the spacing of the reinforcement does not exceed 72 inches.
- Vertical reinforcement shall be Grade 60 minimum. The distance from the face of the soil side of the wall to the center of vertical reinforcement shall be at least 5 inches.
- Soil classes are in accordance with the Unified Soil Classification System. Refer to Table R405.1.
- Unbalanced backfill height is the difference in height of the exterior and interior finish ground levels. Where an interior concrete slab is provided, the unbalanced backfill height shall be measured from the exterior finish ground level to the top of the interior concrete slab.

TABLE R404.1.1(3)
REINFORCED CONCRETE AND MASONRY^a FOUNDATION WALLS

MAXIMUM WALL HEIGHT (feet)	MAXIMUM UNBALANCED BACKFILL HEIGHT ^e (feet)	VERTICAL REINFORCEMENT SIZE AND SPACING ^{b,c} FOR 12-INCH NOMINAL WALL THICKNESS		
		Soil classes ^d		
		GW, GP, SW and SP soils	GM, GC, SM, SM-SC and ML soils	SC, MH, ML-CL and inorganic CL soils
7	4	#4 at 72" o.c.	#4 at 72" o.c.	#4 at 72" o.c.
	5	#4 at 72" o.c.	#4 at 72" o.c.	#4 at 72" o.c.
	6	#4 at 72" o.c.	#4 at 64" o.c.	#4 at 48" o.c.
	7	#4 at 72" o.c.	#4 at 48" o.c.	#5 at 56" o.c.
8	5	#4 at 72" o.c.	#4 at 72" o.c.	#4 at 72" o.c.
	6	#4 at 72" o.c.	#4 at 56" o.c.	#5 at 72" o.c.
	7	#4 at 64" o.c.	#5 at 64" o.c.	#4 at 32" o.c.
	8	#4 at 48" o.c.	#4 at 32" o.c.	#5 at 40" o.c.
9	5	#4 at 72" o.c.	#4 at 72" o.c.	#4 at 72" o.c.
	6	#4 at 72" o.c.	#4 at 56" o.c.	#5 at 64" o.c.
	7	#4 at 56" o.c.	#4 at 40" o.c.	#6 at 64" o.c.
	8	#4 at 64" o.c.	#6 at 64" o.c.	#6 at 48" o.c.
	9	#5 at 56" o.c.	#7 at 72" o.c.	#6 at 40" o.c.

For SI: 1 inch = 25.4 mm, 1 foot = 304.8 mm.

- Mortar shall be Type M or S and masonry shall be laid in running bond.
- Alternative reinforcing bar sizes and spacing having an equivalent cross-sectional area of reinforcement per lineal foot of wall shall be permitted provided the spacing of the reinforcement does not exceed 72 inches.
- Vertical reinforcement shall be Grade 60 minimum. The distance from the face of the soil side of the wall to the center of vertical reinforcement shall be at least 8.75 inches.
- Soil classes are in accordance with the Unified Soil Classification System. Refer to Table R405.1.
- Unbalanced backfill height is the difference in height of the exterior and interior finish ground levels. Where an interior concrete slab is provided, the unbalanced backfill height shall be measured from the exterior finish ground level to the top of the interior concrete slab.

FOUNDATIONS

TABLE R404.1.1(4)
REINFORCED CONCRETE AND MASONRY^a FOUNDATION WALLS

MAXIMUM WALL HEIGHT (feet)	MAXIMUM UNBALANCED BACKFILL HEIGHT ^e (feet)	MINIMUM VERTICAL REINFORCEMENT SIZE AND SPACING ^{b,c} FOR 10-INCH NOMINAL WALL THICKNESS		
		Soil Classes ^d		
		GW, GP, SW and SP soils	GM, GC, SM, SM-SC and ML soils	SC, MH, ML-CL and inorganic CL soils
7	4	#4 at 56" o.c.	#4 at 56" o.c.	#4 at 56" o.c.
	5	#4 at 56" o.c.	#4 at 56" o.c.	#4 at 56" o.c.
	6	#4 at 56" o.c.	#4 at 48" o.c.	#4 at 40" o.c.
	7	#4 at 56" o.c.	#5 at 56" o.c.	#5 at 40" o.c.
8	5	#4 at 56" o.c.	#4 at 56" o.c.	#4 at 48" o.c.
	6	#4 at 56" o.c.	#4 at 48" o.c.	#5 at 56" o.c.
	7	#4 at 48" o.c.	#4 at 32" o.c.	#6 at 56" o.c.
	8	#5 at 56" o.c.	#5 at 40" o.c.	#7 at 56" o.c.
9	5	#4 at 56" o.c.	#4 at 56" o.c.	#4 at 48" o.c.
	6	#4 at 56" o.c.	#4 at 40" o.c.	#4 at 32" o.c.
	7	#4 at 56" o.c.	#5 at 48" o.c.	#6 at 48" o.c.
	8	#4 at 32" o.c.	#6 at 48" o.c.	#4 at 16" o.c.
	9	#5 at 40" o.c.	#6 at 40" o.c.	#7 at 40" o.c.

For SI: 1 inch = 25.4 mm, 1 foot = 304.8 mm.

- a. Mortar shall be Type M or S and masonry shall be laid in running bond.
- b. Alternative reinforcing bar sizes and spacings having an equivalent cross-sectional area of reinforcement per lineal foot of wall shall be permitted provided the spacing of the reinforcement does not exceed 72 inches.
- c. Vertical reinforcement shall be Grade 60 minimum. The distance from the face of the soil side of the wall to the center of vertical reinforcement shall be at least 6.75 inches.
- d. Soil classes are in accordance with the Unified Soil Classification System. Refer to Table R405.1.
- e. Unbalanced backfill height is the difference in height of the exterior and interior finish ground levels. Where an interior concrete slab is provided, the unbalanced backfill height shall be measured from the exterior finish ground level to the top of the interior concrete slab.

R404.1.5 Foundation wall thickness based on walls supported. The thickness of concrete and masonry foundation walls shall not be less than the thickness of the wall supported, except that foundation walls of at least 8-inch (203 mm) nominal thickness shall be permitted under brick-veneered frame walls and under 10-inch-wide (254 mm) cavity walls where the total height of the wall supported, including gables, is not more than 20 feet (6096 mm), provided the requirements of Sections R404.1.1 and R404.1.2 are met.

R404.1.5.1 Pier and curtain wall foundations. Pier and curtain wall foundations shall be permitted to be used to support light-frame construction not more than two stories in height, provided the following requirements are met:

1. All load-bearing walls shall be placed on continuous concrete footings placed integrally with the exterior wall footings.
2. The minimum actual thickness of a load-bearing masonry wall shall be not less than 4 inches (102 mm) nominal or 3³/₈ inches (92 mm) actual thickness, and shall be bonded integrally with piers spaced in accordance with Section R606.8.
3. Piers shall be constructed in accordance with Section R606.5 and Section R606.5.1, and shall be bonded into the load-bearing masonry wall in accordance with Section R608.1.1 or Section R608.1.1.2.
4. The maximum height of a 4-inch (102 mm) load-bearing masonry foundation wall supporting wood framed walls and floors shall not be more than 4 feet (1219 mm) in height.

5. Anchorage shall be in accordance with R403.1.6, Figure R404.1.5(1), or as specified by engineered design accepted by the building official.
6. The unbalanced fill for 4-inch (102 mm) foundation walls shall not exceed 24 inches (610 mm) for solid masonry or 12 inches (305 mm) for hollow masonry.
7. In Seismic Design Categories D₁ and D₂ prescriptive reinforcement shall be provided in the horizontal and vertical directions. Provide minimum horizontal joint reinforcement of two No. 9 gage wires spaced not less than 6 inches (152 mm) or one 1/4-inch (6.4 mm) diameter wire at 10 inches (254 mm) on center vertically. Provide minimum vertical reinforcement of one #4 bar at 48 inches (1220 mm) on center horizontally grouted in place.

R404.1.6 Height above finished grade. Concrete and masonry foundation walls shall extend above the finished grade adjacent to the foundation at all points a minimum of 4 inches (102 mm) where masonry veneer is used and a minimum of 6 inches (152 mm) elsewhere.

R404.1.7 Backfill placement. Backfill shall not be placed against the wall until the wall has sufficient strength and has been anchored to the floor above, or has been sufficiently braced to prevent damage by the backfill.

Exception: Such bracing is not required for walls supporting less than 4 feet (1219 mm) of unbalanced backfill.

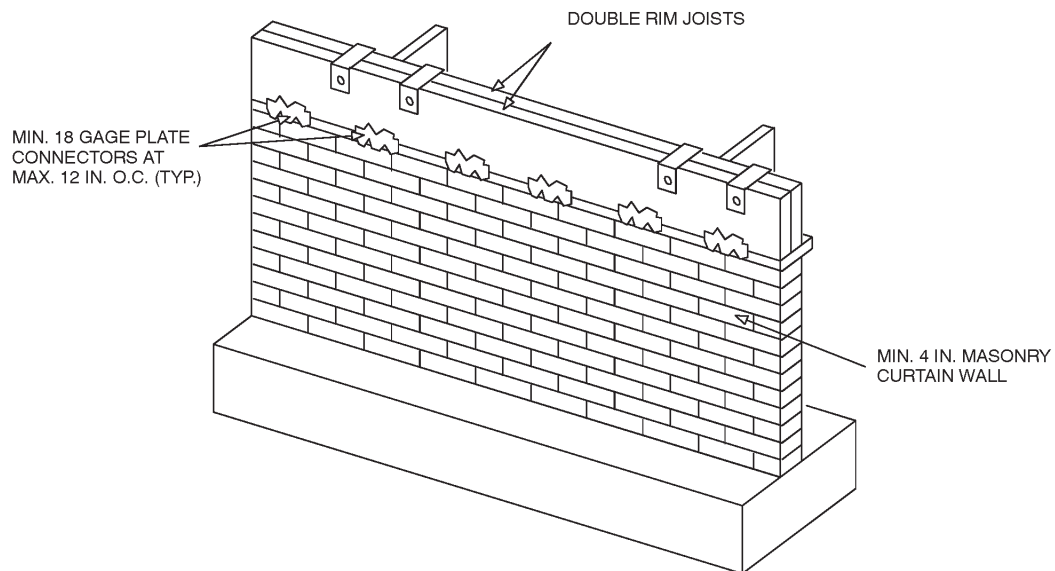
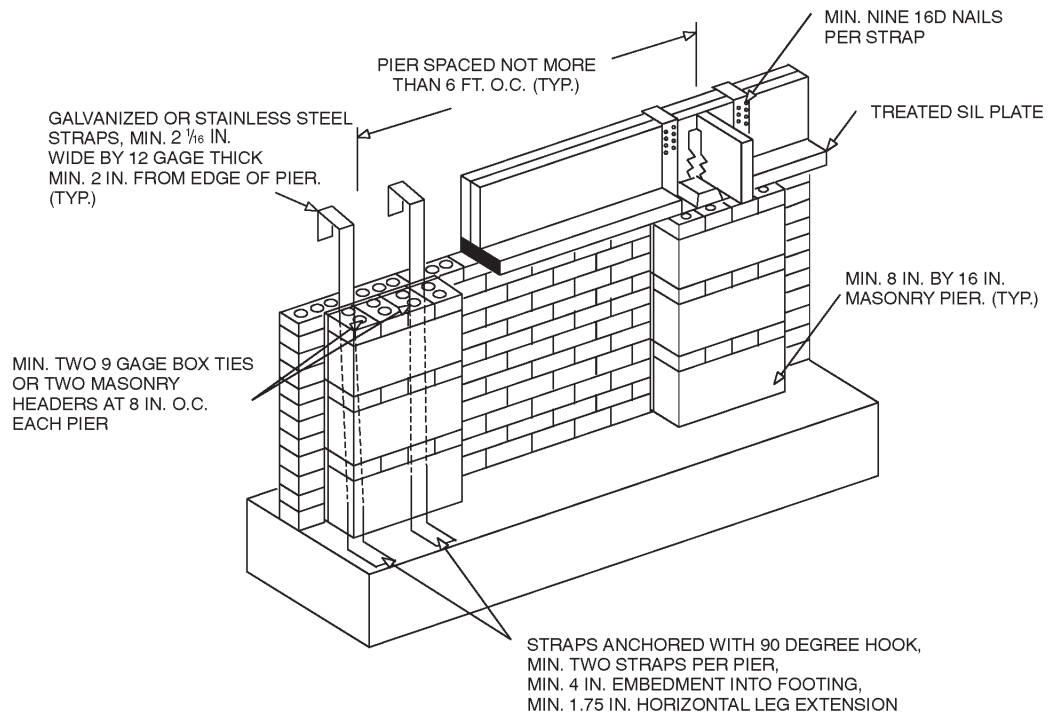

For SI: 1 inch = 25.4 mm, 1 foot = 304.8 mm, 1 degree = 0.79/45 rad.

FIGURE R404.1.5(1)
FOUNDATION WALL CLAY MASONRY CURTAIN WALL WITH CONCRETE MASONRY PIERS

FOUNDATIONS

R404.1.8 Rubble stone masonry. Rubble stone masonry foundation walls shall have a minimum thickness of 16 inches (406 mm), shall not support an unbalanced backfill exceeding 8 feet (2438 mm) in height, shall not support a soil pressure greater than 30 psf (481 kg/m²), and shall not be constructed in Seismic Design Categories D₁ or D₂ as established in Figure R301.2(2).

R404.2 Wood foundation walls. Wood foundation walls shall be constructed in accordance with the provisions of Sections R404.2.1 through R404.2.6 and with the details shown in Figures R403.1(2) and R403.1(3).

R404.2.1 Identification. All load-bearing lumber shall be identified by the grade mark of a lumber grading or inspection agency which has been approved by an accreditation body that complies with DOC PS 20. In lieu of a grade mark, a certificate of inspection issued by a lumber grading or inspection agency meeting the requirements of this section shall be accepted. Wood structural panels shall conform to

DOC PS 1 or DOC PS 2 and shall be identified by a grade mark or certificate of inspection issued by an approved agency.

R404.2.2 Stud size. The studs used in foundation walls shall be 2-inch by 6-inch (51 mm by 152 mm) members. When spaced 16 inches (406 mm) on center, a wood species with an F_b value of not less than 1,250 (8612 kPa) as listed in AF&PA/NDS shall be used. When spaced 12 inches (305 mm) on center, an F_b of not less than 875 (6029 kPa) shall be required.

R404.2.3 Height of backfill. For wood foundations that are not designed and installed in accordance with AF&PA Report No.7, the height of backfill against a foundation wall shall not exceed 4 feet (1219 mm). When the height of fill is more than 12 inches (305 mm) above the interior grade of a crawl space or floor of a basement, the thickness of the plywood sheathing shall meet the requirements of Table R404.2.3.

**TABLE R404.2.3
PLYWOOD GRADE AND THICKNESS FOR WOOD FOUNDATION CONSTRUCTION
(30 pcf equivalent-fluid weight soil pressure)**

HEIGHT OF FILL (inches)	STUD SPACING (inches)	FACE GRAIN ACROSS STUDS			FACE GRAIN PARALLEL TO STUDS		
		Grade ^a	Minimum thickness (inches)	Span rating	Grade ^a	Minimum thickness (inches) ^{b,c}	Span rating
24	12	B	15/32	32/16	A	15/32	32/16
					B	15/32 ^c	32/16
	16	B	15/32	32/16	A	15/32 ^c	32/16
					B	19/32 ^c (4, 5 ply)	40/20
36	12	B	15/32	32/16	A	15/32	32/16
					B	15/32 ^c (4, 5 ply)	32/16
					B	19/32 (4, 5 ply)	40/20
	16	B	15/32 ^c	32/16	A	19/32	40/20
B					23/32	48/24	
48	12	B	15/32	32/16	A	15/32 ^c	32/16
					B	19/32 ^c (4, 5 ply)	40/20
	16	B	19/32	40/20	A	19/32 ^c	40/20
					A	23/32	48/24

For SI: 1 inch = 25.4 mm, 1 foot = 304.8 mm, 1 pound per cubic foot = 0.1572kN/m³.

- a. Plywood shall be of the following minimum grades in accordance with DOC PS 1 or DOC PS 2:
 - 1. DOC PS 1 Plywood grades marked:
 - 1.1. Structural I C-D (Exposure 1)
 - 1.2. C-D (Exposure 1)
 - 2. DOC PS 2 Plywood grades marked:
 - 2.1. Structural I Sheathing (Exposure 1)
 - 2.2. Sheathing (Exposure 1)
 - 3. Where a major portion of the wall is exposed above ground and a better appearance is desired, the following plywood grades marked exterior are suitable:
 - 3.1. Structural I A-C, Structural I B-C or Structural I C-C (Plugged) in accordance with DOC PS 1
 - 3.2. A-C Group 1, B-C Group 1, C-C (Plugged) Group 1 or MDO Group 1 in accordance with DOC PS 1
 - 3.3. Single Floor in accordance with DOC PS 1 or DOC PS 2
- b. Minimum thickness 15/32 inch, except crawl space sheathing may be 3/8 inch for face grain across studs 16 inches on center and maximum 2-foot depth of unequal fill.
- c. For this fill height, thickness and grade combination, panels that are continuous over less than three spans (across less than three stud spacings) require blocking 16 inches above the bottom plate. Offset adjacent blocks and fasten through studs with two 16d corrosion-resistant nails at each end.

R404.2.4 Backfilling. Wood foundation walls shall not be backfilled until the basement floor and first floor have been constructed or the walls have been braced. For crawl space construction, backfill or bracing shall be installed on the interior of the walls prior to placing backfill on the exterior.

R404.2.5 Drainage and dampproofing. Wood foundation basements shall be drained and dampproofed in accordance with Sections R405 and R406, respectively.

R404.2.6 Fastening. Wood structural panel foundation wall sheathing shall be attached to framing in accordance with Table R602.3(1) and Section R402.1.1.

R404.3 Wood sill plates. Wood sill plates shall be a minimum of 2-inch by 4-inch (51 mm by 102 mm) nominal lumber. Sill plate anchorage shall be in accordance with Sections R403.1.6 and R602.11.

R404.4 Insulating concrete form foundation walls. Insulating concrete form (ICF) foundation walls shall be designed and constructed in accordance with the provisions of this section or in accordance with the provisions of ACI 318. When ACI 318 or the provisions of this section are used to design insulating concrete form foundation walls, project drawings, typical details and specifications are not required to bear the seal of the architect or engineer responsible for design unless otherwise required by the state law of the jurisdiction having authority.

R404.4.1 Applicability limits. The provisions of this section shall apply to the construction of insulating concrete form foundation walls for buildings not greater than 60 feet (18 288 mm) in plan dimensions, and floors not greater than 32 feet (9754 mm) or roofs not greater than 40 feet (12 192 mm) in clear span. Buildings shall not exceed two stories in height above-grade with each story not greater than 10 feet (3048 mm) high. Foundation walls constructed in accordance with the provisions of this section shall be limited to buildings subjected to a maximum ground snow load of 70 psf (3.35 kN/m²) and located in Seismic Design Category A, B or C.

R404.4.2 Flat insulating concrete form wall systems. Flat ICF wall systems shall comply with Figure R611.3, shall have a minimum concrete thickness of 5.5 inches (140 mm), and shall have reinforcement in accordance with Table R404.4(1), R404.4(2) or R404.4(3).

R404.4.3 Waffle-grid insulating concrete form wall systems. Waffle-grid wall systems shall have a minimum nominal concrete thickness of 6 inches (152 mm) for the horizontal and vertical concrete members (cores) and shall be reinforced in accordance with Table R404.4(4). The minimum core dimension shall comply with Table R611.4(2) and Figure R611.4.

R404.4.4 Screen-grid insulating concrete form wall systems. Screen-grid ICF wall systems shall have a minimum nominal concrete thickness of 6 inches (152 mm) for the

horizontal and vertical concrete members (cores). The minimum core dimensions shall comply with Table R611.4(2) and Figure R611.5. Walls shall have reinforcement in accordance with Table R404.4(5).

R404.4.5 Concrete material. Ready-mixed concrete for insulating concrete form walls shall be in accordance with Section R402.2. Maximum slump shall not be greater than 6 inches (152 mm) as determined in accordance with ASTM C 143. Maximum aggregate size shall not be larger than ³/₄ inch (19.1 mm).

Exception: Concrete mixes conforming to the ICF manufacturer's recommendations.

R404.4.6 Reinforcing steel.

R404.4.6.1 General. Reinforcing steel shall meet the requirements of ASTM A 615, A 706 or A 996. The minimum yield strength of reinforcing steel shall be 40,000 psi (Grade 40) (276 mPa). Vertical and horizontal wall reinforcements shall be placed no closer to the outside face of the wall than one-half the wall thickness. Steel reinforcement for foundation walls shall have concrete cover in accordance with ACI 318.

Exception: Where insulated concrete forms are used and the form remains in place as cover for the concrete, the minimum concrete cover for the reinforcing steel is permitted to be reduced to ³/₄ inch (19.1 mm).

R404.4.6.2 Horizontal reinforcement. When vertical reinforcement is required, ICF foundation walls shall have horizontal reinforcement in accordance with this section. ICF foundation walls up to 8 feet (2438 mm) in height shall have a minimum of one continuous No. 4 horizontal reinforcing bar placed at 48 inches (1219 mm) on center with one bar located within 12 inches (305 mm) of the top of the wall story. ICF Foundation walls greater than 8 feet (2438 mm) in height shall have a minimum of one continuous No. 4 horizontal reinforcing bar placed at 36 inches (914 mm) on center with one bar located within 12 inches (305 mm) of the top of the wall story.

R404.4.6.3 Wall openings. Vertical wall reinforcement required by Section R404.4.2, R404.4.3 or R404.4.4 that is interrupted by wall openings shall have additional vertical reinforcement of the same size placed within 12 inches (305 mm) of each side of the opening.

R404.4.7 Foam plastic insulation. Foam plastic insulation in insulating concrete foam construction shall comply with this section.

R404.4.7.1 Material. Insulating concrete form material shall meet the surface burning characteristics of Section R314.1.1. A thermal barrier shall be provided on the building interior in accordance with Section R314.1.2.

FOUNDATIONS

TABLE R404.4(1)
5.5-INCH THICK FLAT ICF FOUNDATION WALLS^{a,b,c,d}

HEIGHT OF BASEMENT WALL (feet)	MAXIMUM UNBALANCED BACKFILL HEIGHT ^e (feet)	MINIMUM VERTICAL REINFORCEMENT SIZE AND SPACING ^f		
		Soil group I ^f	Soil group II ^f	Soil group III ^f
8	4	#4@48"	#4@48"	#4@48"
	5	#4@48"	#3@12"; #4@22"; #5@32"	#3@8"; #4@14"; #5@20"; #6@26"
	6	#3@12"; #4@22"; #5@30"	#3@8"; #4@14"; #5@20"; #6@24"	#3@6"; #4@10"; #5@14"; #6@20"
	7	#3@8"; #4@14"; #5@22"; #6@26"	#3@5"; #4@10"; #5@14"; #6@18"	#3@4"; #4@6"; #5@10"; #6@14"
9	4	#4@48"	#4@48"	#4@48"
	5	#4@48"	#3@12"; #4@20"; #5@28"; #6@36"	#3@8"; #4@14"; #5@20"; #6@22"
	6	#3@10"; #4@20"; #5@28"; #6@34"	#3@6"; #4@12"; #5@18"; #6@20"	#4@8"; #5@14"; #6@16"
	7	#3@8"; #4@14"; #5@20"; #6@22"	#4@8"; #5@12"; #6@16"	#4@6"; #5@10"; #6@12"
	8	#3@6"; #4@10"; #5@14"; #6@16"	#4@6"; #5@10"; #6@12"	#4@4"; #5@6"; #6@8"
10	4	#4@48"	#4@48"	#4@48"
	5	#4@48"	#3@10"; #4@18"; #5@26"; #6@30"	#3@6"; #4@14"; #5@18"; #6@20"
	6	#3@10"; #4@18"; #5@24"; #6@30"	#3@6"; #4@12"; #5@16"; #6@18"	#3@4"; #4@8"; #5@12"; #6@14"
	7	#3@6"; #4@12"; #5@16"; #6@18"	#3@4"; #4@8"; #5@12"	#4@6"; #5@8"; #6@10"
	8	#4@8"; #5@12"; #6@14"	#4@6"; #5@8"; #6@12"	#4@4"; #5@6"; #6@8"
	9	#4@6"; #5@10"; #6@12"	#4@4"; #5@6"; #6@8"	#5@4"; #6@6"

For SI: 1 inch = 25.4 mm, 1 foot = 304.8 mm, 1 pound per square inch = 6.895kPa.

- a. This table is based on concrete with a minimum specified concrete strength of 2500 psi, reinforcing steel with a minimum yield strength of 40,000 psi. When reinforcing steel with a minimum yield strength of 60,000 psi is used, the spacing of the reinforcement shall be increased to 1.5 times the spacing value in the table but in no case greater than 48 inches on center.
- b. This table is not intended to prohibit the use of an ICF manufacturer's tables based on engineering analysis in accordance with ACI 318.
- c. Deflection criteria: $L/240$.
- d. Interpolation between rebar sizes and spacing is not permitted.
- e. Unbalanced backfill height is the difference in height of the exterior and interior finished ground. Where an interior concrete slab is provided, the unbalanced backfill height shall be measured from the exterior finished ground level to the top of the interior concrete slab.
- f. Soil classes are in accordance with the Unified Soil Classification System. Refer to Table R405.1.

TABLE R404.4(2)
7.5-INCH THICK FLAT ICF FOUNDATION WALLS^{a, b, c, d, e}

HEIGHT OF BASEMENT WALL (feet)	MAXIMUM UNBALANCED BACKFILL HEIGHT ^f (feet)	MINIMUM VERTICAL REINFORCEMENT SIZE AND SPACING ^g		
		Soil group I ^g	Soil group II ^g	Soil group III ^g
8	6	N/R	N/R	N/R
	7	N/R	#3@8"; #4@14"; #5@20"; #6@28"	#3@6"; #4@10"; #5@16"; #6@20"
9	6	N/R	N/R	#3@8"; #4@14"; #5@20"; #6@28"
	7	N/R	#3@6"; #4@12"; #5@18"; #6@26"	#3@4"; #4@8"; #5@14"; #6@18"
	8	#3@8"; #4@14"; #5@22"; #6@28"	#3@4"; #4@8"; #5@14"; #6@18"	#3@4"; #4@6"; #5@10"; #6@14"
	6	N/R	N/R	#3@6"; #4@12"; #5@18"; #6@26"
10	7	N/R	#3@6"; #4@12"; #5@18"; #6@24"	#3@4"; #4@8"; #5@12"; #6@18"
	8	#3@6"; #4@12"; #5@20"; #6@26"	#3@4"; #4@8"; #5@12"; #6@16"	#3@4"; #4@6"; #5@8"; #6@12"
	9	#3@6"; #4@10"; #5@14"; #6@20"	#3@4"; #4@6"; #5@10"; #6@12"	#4@4"; #5@6"; #6@10"

For SI: 1 inch = 25.4 mm, 1 foot = 304.8 mm, 1 pound per square inch = 6.895kPa.

- a. This table is based on concrete with a minimum specified concrete strength of 2500 psi, reinforcing steel with a minimum yield strength of 40,000 psi. When reinforcing steel with a minimum yield strength of 60,000 psi is used, the spacing of the reinforcement shall be increased to 1.5 times the spacing value in the table.
- b. This table is not intended to prohibit the use of an ICF manufacturer's tables based on engineering analysis in accordance with ACI 318.
- c. N/R denotes "not required."
- d. Deflection criteria: $L/240$.
- e. Interpolation between rebar sizes and spacing is not permitted.
- f. Unbalanced backfill height is the difference in height of the exterior and interior finished ground. Where an interior concrete slab is provided, the unbalanced backfill height shall be measured from the exterior finished ground level to the top of the interior concrete slab.
- g. Soil classes are in accordance with the Unified Soil Classification System. Refer to Table R405.1.

TABLE R404.4(3)
9.5-INCH THICK FLAT ICF FOUNDATION WALLS^{a, b, c, d, e}

HEIGHT OF BASEMENT WALL (feet)	MAXIMUM UNBALANCED BACKFILL HEIGHT ^f (feet)	MINIMUM VERTICAL REINFORCEMENT SIZE AND SPACING ^g		
		Soil I ^g	Soil II ^g	Soil III ^g
8	7	N/R	N/R	N/R
9	6	N/R	N/R	N/R
	7	N/R	N/R	#3@6"; #4@12"; #5@18"; #6@26"
	8	N/R	#3@6"; #4@12"; #5@18"; #6@26"	#3@4"; #4@8"; #5@14"; #6@18"
10	5	N/R	N/R	N/R
	6	N/R	N/R	#3@10"; #4@18"; #5@26"; #6@36"
	7	N/R	N/R	#3@6"; #4@10"; #5@18"; #6@24"
	8	N/R	#3@6"; #4@12"; #5@16"; #6@24"	#3@4"; #4@8"; #5@12"; #6@16"
	9	N/R	#3@4"; #4@8"; #5@12"; #6@18"	#3@4"; #4@6"; #5@10"; #6@12"

For SI: 1 inch = 25.4 mm, 1 foot = 304.8 mm, 1 pound per square inch = 6.895kPa.

- a. This table is based on concrete with a minimum specified concrete strength of 2500 psi, reinforcing steel with a minimum yield strength of 40,000 psi. When reinforcing steel with a minimum yield strength of 60,000 psi is used, the spacing of the reinforcement shall be increased to 1.5 times the spacing value in the table.
- b. This table is not intended to prohibit the use of an ICF manufacturer's tables based on engineering analysis in accordance with ACI 318.
- c. N/R denotes "not required."
- d. Deflection criteria: $L/240$.
- e. Interpolation between rebar sizes and spacing is not permitted.
- f. Unbalanced backfill height is the difference in height of the exterior and interior finished ground. Where an interior concrete slab is provided, the unbalanced backfill height shall be measured from the exterior finished ground level to the top of the interior concrete slab.
- g. Soil classes are in accordance with the Unified Soil Classification System. Refer to Table R405.1.

FOUNDATIONS

TABLE R404.4(4)
WAFFLE GRID ICF FOUNDATION WALLS^{a, b, c, d, e}

MINIMUM NOMINAL WALL THICKNESS ^f (inches)	HEIGHT OF BASEMENT WALL (feet)	MAXIMUM UNBALANCED BACKFILL HEIGHT ^g (feet)	MINIMUM VERTICAL REINFORCEMENT SIZE AND SPACING ^h		
			Soil group I ^h	Soil group II ^h	Soil group III ^h
6	8	4	#4@48"	#3@12"; #4@24"	#3@12"
		5	#3@12"; #5@24"	#4@12"	#7@12"
		6	#4@12"	Design required	Design required
		7	#7@12"	Design required	Design required
	9	4	#4@48"	#3@12"; #5@24"	#3@12"
		5	#3@12"	#4@12"	Design required
		6	#5@12"	Design required	Design required
		7	Design required	Design required	Design required
	10	4	#4@48"	#4@12"	#5@12"
		5	#3@12"	Design required	Design required
		6	Design required	Design required	Design required
		7	Design required	Design required	Design required
8	8	4	N/R	N/R	N/R
		5	N/R	#3@12"; #4@24"; #5@36"	#3@12"; #5@24"
		6	#3@12"; #4@24"; #5@36"	#4@12"; #5@24"	#4@12"
		7	#3@12"; #6@24"	#4@12"	#5@12"
	9	4	N/R	N/R	N/R
		5	N/R	#3@12"; #5@24"	#3@12"; #5@24"
		6	#3@12"; #4@24"	#4@12"	#4@12"
		7	#4@12"; #5@24"	#5@12"	#5@12"
	10	8	#4@12"	#5@12"	#8@12"
		4	N/R	#3@12"; #4@24"; #6@36"	#3@12"; #5@24"
		5	N/R	#3@12"; #4@24"; #6@36"	#4@12"; #5@24"
		6	#3@12"; #5@24"	#4@12"	#5@12"
		7	#4@12"	#5@12"	#6@12"
	8	#4@12"	#6@12"	Design required	
	9	#5@12"	Design required	Design required	

For SI: 1 inch = 25.4 mm, 1 foot = 304.8 mm, 1 pound per square foot = 0.0479kN/m².

- a. This table is based on concrete with a minimum specified concrete strength of 2500 psi, reinforcing steel with a minimum yield strength of 40,000 psi. When reinforcing steel with a minimum yield strength of 60,000 psi is used, the spacing of the reinforcement shall be increased 12 inches but in no case greater than 48 inches on center.
- b. This table is not intended to prohibit the use of an ICF manufacturer's tables based on engineering analysis in accordance with ACI 318.
- c. N/R denotes "not required."
- d. Deflection criteria: $L/240$.
- e. Interpolation between rebar sizes and spacing is not permitted.
- f. Refer to Table R611.4(2) for wall dimensions.
- g. Unbalanced backfill height is the difference in height of the exterior and interior finished ground. Where an interior concrete slab is provided, the unbalanced backfill height shall be measured from the exterior finished ground level to the top of the interior concrete slab.
- h. Soil classes are in accordance with the Unified Soil Classification System. Refer to Table R405.1.

TABLE R404.4(5)
SCREEN-GRID ICF FOUNDATION WALLS^{a, b, c, d, e}

MINIMUM NOMINAL WALL THICKNESS ^f (inches)	MAXIMUM WALL HEIGHT (feet)	MAXIMUM UNBALANCED BACKFILL HEIGHT ^g (feet)	MINIMUM VERTICAL REINFORCEMENT SIZE AND SPACING			
			Soil classes			
			Soil group I ^h	Soil group II ^h	Soil group III ^h	
6	8	4	#4@48"	#3@12"; #4@24"; #5@36"	#3@12"; #5@24"	
		5	#3@12"; #4@24"	#3@12"	#4@12"	
		6	#4@12"	#5@12"	Design required	
		7	#4@12"	Design required	Design required	
	9	4	#4@48"	#3@12"; #4@24"	#3@12"; #6@24"	
		5	#3@12"; #5@24"	#4@12"	#7@12"	
		6	#4@12"	Design required	Design required	
		7	Design required	Design required	Design required	
	10	8	Design required	Design required	Design required	
		4	#4@48"	#3@12"; #5@24"	#3@12"	
		5	#3@12"	#4@12"	#7@12"	
		6	#4@12"	Design required	Design required	
			7	Design required	Design required	Design required
			8	Design required	Design required	Design required

For SI: 1 inch = 25.4 mm, 1 foot = 304.8 mm, 1 pound per square foot = 0.0479kN/m².

- a. This table is based on concrete with a minimum specified concrete strength of 2500 psi, reinforcing steel with a minimum yield strength of 40,000 psi. When reinforcing steel with a minimum yield strength of 60,000 psi is used, the spacing of the reinforcement in the shaded cells shall be increased 12 inches.
- b. This table is not intended to prohibit the use of an ICF manufacturer's tables based on engineering analysis in accordance with ACI 318.
- c. N/R denotes "not required."
- d. Deflection criteria: $L/240$.
- e. Interpolation between rebar sizes and spacing is not permitted.
- f. Refer to Table R611.4(2) for wall dimensions.
- g. Unbalanced backfill height is the difference in height of the exterior and interior finished ground. Where an interior concrete slab is provided, the unbalanced backfill height shall be measured from the exterior finished ground level to the top of the interior concrete slab.
- h. Soil classes are in accordance with the Unified Soil Classification System. Refer to Table R405.1.

R404.4.7.2 Termite hazards. In areas where hazard of termite damage is very heavy in accordance with Figure R301.2(6), foam plastic insulation shall be permitted below grade on foundation walls in accordance with one of the following conditions:

1. When in addition to the requirements in Section R320.1, an approved method of protecting the foam plastic and structure from subterranean termite damage is provided.
2. The structural members of walls, floors, ceilings and roofs are entirely of noncombustible materials or pressure preservatively treated wood.
3. On the interior side of basement walls.

R404.4.8 Foundation wall thickness based on walls supported. The thickness of ICF foundation walls shall not be less than the thickness of the wall supported above.

R404.4.9 Height above finished ground. ICF foundation walls shall extend above the finished ground adjacent to the foundation at all points a minimum of 4 inches (102 mm) where masonry veneer is used and a minimum of 6 inches (152 mm) elsewhere.

R404.4.10 Backfill placement. Backfill shall be placed in accordance with Section R404.1.7.

R404.4.11 Drainage and dampproofing/waterproofing. ICF foundation basements shall be drained and dampproofed/waterproofed in accordance with Sections R405 and R406.

SECTION R405
FOUNDATION DRAINAGE

R405.1 Concrete or masonry foundations. Drains shall be provided around all concrete or masonry foundations that retain earth and enclose habitable or usable spaces located below grade. Drainage tiles, gravel or crushed stone drains, perforated pipe or other approved systems or materials shall be installed at or below the area to be protected and shall discharge by gravity or mechanical means into an approved drainage system. Gravel or crushed stone drains shall extend at least 1 foot (305 mm) beyond the outside edge of the footing and 6 inches (153 mm) above the top of the footing and be covered with an approved filter membrane material. The top of open joints of drain tiles shall be protected with strips of building paper, and the drainage tiles

FOUNDATIONS

or perforated pipe shall be placed on a minimum of 2 inches (51 mm) of washed gravel or crushed rock at least one sieve size larger than the tile joint opening or perforation and covered with not less than 6 inches (153 mm) of the same material.

Exception: A drainage system is not required when the foundation is installed on well-drained ground or sand-gravel mixture soils according to the Unified Soil Classification System, Group I Soils, as detailed in Table R405.1.

R405.2 Wood foundations. Wood foundations enclosing habitable or usable spaces located below grade shall be adequately drained in accordance with Sections R405.2.1 through R405.2.3.

R405.2.1 Base. A porous layer of gravel, crushed stone or coarse sand shall be placed to a minimum thickness of 4 inches (102 mm) under the basement floor. Provision shall

be made for automatic draining of this layer and the gravel or crushed stone wall footings.

R405.2.2 Moisture barrier. A 6-mil-thick (0.15 mm) polyethylene moisture barrier shall be applied over the porous layer with the basement floor constructed over the polyethylene.

R405.2.3 Drainage system. In other than Group I soils, a sump shall be provided to drain the porous layer and footings. The sump shall be at least 24 inches (610 mm) in diameter or 20 inches square (0.0129 m²), shall extend at least 24 inches (610 mm) below the bottom of the basement floor and shall be capable of positive gravity or mechanical drainage to remove any accumulated water. The drainage system shall discharge into an approved sewer system or to daylight.

TABLE R405.1
PROPERTIES OF SOILS CLASSIFIED ACCORDING TO THE UNIFIED SOIL CLASSIFICATION SYSTEM

SOIL GROUP	UNIFIED SOIL CLASSIFICATION SYSTEM SYMBOL	SOIL DESCRIPTION	DRAINAGE CHARACTERISTICS ^a	FROST HEAVE POTENTIAL	VOLUME CHANGE POTENTIAL EXPANSION ^b
Group I	GW	Well-graded gravels, gravel sand mixtures, little or no fines.	Good	Low	Low
	GP	Poorly graded gravels or gravel sand mixtures, little or no fines.	Good	Low	Low
	SW	Well-graded sands, gravelly sands, little or no fines.	Good	Low	Low
	SP	Poorly graded sands or gravelly sands, little or no fines.	Good	Low	Low
	GM	Silty gravels, gravel-sand-silt mixtures.	Good	Medium	Low
	SM	Silty sand, sand-silt mixtures.	Good	Medium	Low
Group II	GC	Clayey gravels, gravel-sand-clay mixtures.	Medium	Medium	Low
	SC	Clayey sands, sand-clay mixture.	Medium	Medium	Low
	ML	Inorganic silts and very fine sands, rock flour, silty or clayey fine sands or clayey silts with slight plasticity.	Medium	High	Low
	CL	Inorganic clays of low to medium plasticity, gravelly clays, sandy clays, silty clays, lean clays.	Medium	Medium	Medium to Low
Group III	CH	Inorganic clays of high plasticity, fat clays.	Poor	Medium	High
	MH	Inorganic silts, micaceous or diatomaceous fine sandy or silty soils, elastic silts.	Poor	High	High
Group IV	OL	Organic silts and organic silty clays of low plasticity.	Poor	Medium	Medium
	OH	Organic clays of medium to high plasticity, organic silts.	Unsatisfactory	Medium	High
	Pt	Peat and other highly organic soils.	Unsatisfactory	Medium	High

For SI: 1 inch = 25.4 mm.

- a. The percolation rate for good drainage is over 4 inches per hour, medium drainage is 2 inches to 4 inches per hour, and poor is less than 2 inches per hour.
- b. Soils with a low potential expansion typically have a plasticity index (PI) of 0 to 15, soils with a medium potential expansion have a PI of 10 to 35 and soils with a high potential expansion have a PI greater than 20.

SECTION R406 FOUNDATION WATERPROOFING AND DAMPPROOFING

R406.1 Concrete and masonry foundation dampproofing.

Except where required to be waterproofed by Section R406.2, foundation walls that retain earth and enclose habitable or usable spaces located below grade shall be dampproofed from the top of the footing to the finished grade. Masonry walls shall have not less than $\frac{3}{8}$ inch (9.5 mm) portland cement parging applied to the exterior of the wall. The parging shall be dampproofed with a bituminous coating, 3 pounds per square yard (1.63 kg/m²) of acrylic modified cement, $\frac{1}{8}$ -inch (3.2 mm) coat of surface-bonding mortar complying with ASTM C 887 or any material permitted for waterproofing in Section R406.2. Concrete walls shall be dampproofed by applying any one of the above listed dampproofing materials or any one of the waterproofing materials listed in Section R406.2 to the exterior of the wall.

R406.2 Concrete and masonry foundation waterproofing.

In areas where a high water table or other severe soil-water conditions are known to exist, exterior foundation walls that retain earth and enclose habitable or usable spaces located below grade shall be waterproofed with a membrane extending from the top of the footing to the finished grade. The membrane shall consist of 2-ply hot-mopped felts, 55 pound (25 kg) roll roofing, 6-mil (0.15 mm) polyvinyl chloride, 6-mil (0.15 mm) polyethylene or 40-mil (1 mm) polymer-modified asphalt. The joints in the membrane shall be lapped and sealed with an adhesive compatible with the waterproofing membrane.

Exception: Organic solvent based products such as hydrocarbons, chlorinated hydrocarbons, ketones and esters shall not be used for ICF walls with expanded polystyrene form material. Plastic roofing cements, acrylic coatings, latex coatings, mortars and pargings are permitted to be used to seal ICF walls. Cold setting asphalt or hot asphalt shall conform to type C of ASTM D 449. Hot asphalt shall be applied at a temperature of less than 200 degrees.

R406.3 Dampproofing for wood foundations. Wood foundations enclosing habitable or usable spaces located below grade shall be dampproofed in accordance with Sections R406.3.1 through R406.3.4.

R406.3.1 Panel joint sealed. Plywood panel joints in the foundation walls shall be sealed full length with a caulking compound capable of producing a moisture-proof seal under the conditions of temperature and moisture content at which it will be applied and used.

R406.3.2 Below-grade moisture barrier. A 6-mil-thick (0.15 mm) polyethylene film shall be applied over the below-grade portion of exterior foundation walls prior to backfilling. Joints in the polyethylene film shall be lapped 6 inches (152 mm) and sealed with adhesive. The top edge of the polyethylene film shall be bonded to the sheathing to form a seal. Film areas at grade level shall be protected from mechanical damage and exposure by a pressure preservatively treated lumber or plywood strip attached to the wall several inches above finish grade level and extend-

ing approximately 9 inches (229 mm) below grade. The joint between the strip and the wall shall be caulked full length prior to fastening the strip to the wall. Other coverings appropriate to the architectural treatment may also be used. The polyethylene film shall extend down to the bottom of the wood footing plate but shall not overlap or extend into the gravel or crushed stone footing.

R406.3.3 Porous fill. The space between the excavation and the foundation wall shall be backfilled with the same material used for footings, up to a height of 1 foot (305 mm) above the footing for well-drained sites, or one-half the total back-fill height for poorly drained sites. The porous fill shall be covered with strips of 30-pound (13.6 kg) asphalt paper or 6-mil (0.15 mm) polyethylene to permit water seepage while avoiding infiltration of fine soils.

R406.3.4 Backfill. The remainder of the excavated area shall be backfilled with the same type of soil as was removed during the excavation.

SECTION R407 COLUMNS

R407.1 Wood column protection. Wood columns shall be protected against decay as set forth in Section R319.

R407.2 Steel column protection. All surfaces (inside and outside) of steel columns shall be given a shop coat of rust-inhibitive paint, except for corrosion-resistant steel and steel treated with coatings to provide corrosion resistance.

R407.3 Structural requirements. The columns shall be restrained to prevent lateral displacement at the bottom end. Wood columns shall not be less in nominal size than 4 inches by 4 inches (102 mm by 102 mm) and steel columns shall not be less than 3-inch-diameter (76 mm) standard pipe or approved equivalent.

Exception: Columns no more than 48 inches (1219 mm) in height on a pier or footing are exempt from the bottom end lateral displacement requirement within underfloor areas enclosed by a continuous foundation (see Figure R502.9). < ||

SECTION R408 UNDER-FLOOR SPACE

R408.1 Ventilation. The under-floor space between the bottom of the floor joists and the earth under any building (except space occupied by a basement or cellar) shall be provided with ventilation openings through foundation walls or exterior walls. The minimum net area of ventilation openings shall not be less than 1 square foot for each 150 square feet (0.67 m² for each 14 m²) of under-floor space area. One such ventilating opening shall be within 3 feet (914 mm) of each corner of said building.

R408.2 Openings for under-floor ventilation. The minimum net area of ventilation openings shall not be less than 1 square foot (0.0929 m²) for each 150 square feet (100 m²) of under-floor space area. One such ventilating opening shall be within 3

FOUNDATIONS

feet (914 mm) of each corner of the building. Ventilation openings shall be covered for their height and width with any of the following materials provided that the least dimension of the covering shall not exceed 1/4 inch (6.4 mm):

1. Perforated sheet metal plates not less than 0.070 inch (1.8 mm) thick.
2. Expanded sheet metal plates not less than 0.047 inch (1.2 mm) thick.
3. Cast-iron grills or grating.
4. Extruded load-bearing brick vents.
5. Hardware cloth of 0.035 inch (0.89 mm) wire or heavier.
6. Corrosion-resistant wire mesh, with the least dimension being 1/8 inch (3.2 mm).

Exceptions:

1. Where warranted by climatic conditions, ventilation openings to the outdoors are not required if ventilation openings to the interior are provided.
2. The total area of ventilation openings may be reduced to 1/1500 of the under-floor area where the ground surface is treated with an approved ground cover material and the required openings are placed so as to provide cross-ventilation of the space. The installation of operable louvers shall not be prohibited.
3. Under-floor spaces used as supply plenums for distribution of heated and cooled air shall comply with the requirements of Section M1601.4
4. Ventilation openings are not required where continuously operated mechanical ventilation is provided at a rate of 1.0 cfm (0.47 L/s) for each 50 square feet (5 m²) of under-floor space floor area and ground surface is covered with an approved ground cover material.
5. Ventilation openings are not required when the ground surface is covered with an approved ground cover material, the space is supplied with conditioned air and the perimeter walls are insulated in accordance with Section N1102.1.7.
6. Ventilation openings shall be permitted to be omitted on one side.

R408.3 Access. Access shall be provided to all under-floor spaces. Access openings through the floor shall be a minimum of 18 inches by 24 inches (457 mm by 610 mm). Openings through a perimeter wall shall be 16 inches by 24 inches (407 mm by 610 mm). When any portion of the through wall access is below grade, an areaway of not less than 16 inches by 24 inches shall be provided. The bottom of the areaway shall be below the threshold of the access opening. Through wall access openings shall not be located under a door to the residence. See Section M1305.1.4 for access requirements where mechanical equipment is located under floors.

R408.4 Removal of debris. The under-floor grade shall be cleaned of all vegetation and organic material. All wood forms used for placing concrete shall be removed before a building is occupied or used for any purpose. All construction materials shall be removed before a building is occupied or used for any purpose.

R408.5 Finished grade. The finished grade of under-floor surface may be located at the bottom of the footings; however, where there is evidence that the groundwater table can rise to within 6 inches (152 mm) of the finished floor at the building perimeter or where there is evidence that the surface water does not readily drain from the building site, the grade in the under-floor space shall be as high as the outside finished grade, unless an approved drainage system is provided.

R408.6 Flood resistance. For buildings located in areas prone to flooding as established by the local jurisdiction, the walls enclosing the underfloor space shall be provided with flood openings in accordance with Section R327.2.2.

1. Walls enclosing the under-floor space shall be provided with flood openings in accordance with Section R323.2.2.
2. The finished ground level of the under-floor space shall be equal to or higher than the outside finished ground level.

Exception: Under-floor spaces that meet the requirements of FEMA/FIA TB 11-1.